

TASCAM

TEAC Professional Division

D00978720A

MD-CD1MKII

Minidisc Deck/CD Player



MDLP MP3

OWNER'S MANUAL

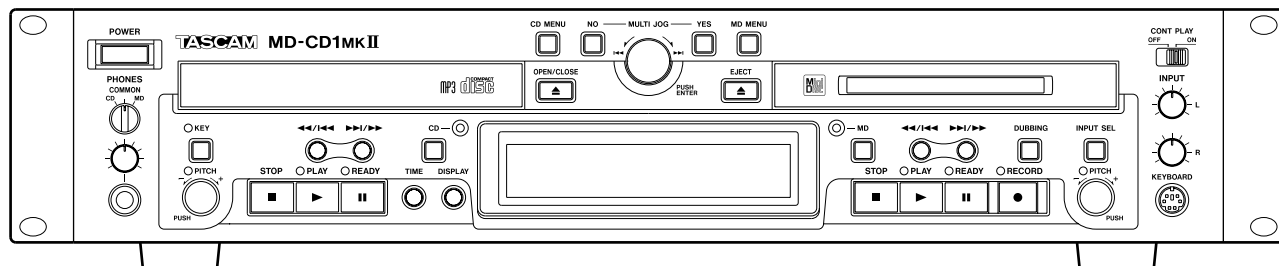

IMPORTANT SAFETY PRECAUTIONS



CAUTION: TO REDUCE THE RISK OF ELECTRIC SHOCK, DO NOT REMOVE COVER (OR BACK). NO USER-SERVICEABLE PARTS INSIDE. REFER SERVICING TO QUALIFIED SERVICE PERSONNEL.



The lightning flash with arrowhead symbol, within an equilateral triangle, is intended to alert the user to the presence of uninsulated “dangerous voltage” within the product’s enclosure that may be of sufficient magnitude to constitute a risk of electric shock to persons.



The exclamation point within an equilateral triangle is intended to alert the user to the presence of important operating and maintenance (servicing) instructions in the literature accompanying the appliance.

This appliance has a serial number located on the rear panel. Please record the model number and serial number and retain them for your records.

Model number _____
Serial number _____

WARNING: TO PREVENT FIRE OR SHOCK HAZARD, DO NOT EXPOSE THIS APPLIANCE TO RAIN OR MOISTURE.

For U.S.A

TO THE USER

This equipment has been tested and found to comply with the limits for a Class A digital device, pursuant to Part 15 of the FCC Rules. These limits are designed to provide reasonable protection against harmful interference when the equipment is operated in a commercial environment. This equipment generates, uses, and can radiate radio frequency energy and, if not installed and used in accordance with the instruction manual, may cause harmful interference to radio communications.

Operation of this equipment in a residential area is likely to cause harmful interference in which case the user will be required to correct the interference at his own expense.

CAUTION

Changes or modifications to this equipment not expressly approved by TEAC CORPORATION for compliance could void the user’s authority to operate this equipment.

For the consumers in Europe

WARNING

This is a Class A product. In a domestic environment, this product may cause radio interference in which case the user may be required to take adequate measures.

Pour les utilisateurs en Europe

AVERTISSEMENT

Il s’agit d’un produit de Classe A. Dans un environnement domestique, cet appareil peut provoquer des interférences radio, dans ce cas l’utilisateur peut être amené à prendre des mesures appropriées.

Für Kunden in Europa

Warnung

Dies ist eine Einrichtung, welche die Funk-Entstörung nach Klasse A besitzt. Diese Einrichtung kann im Wohnbereich Funkstörungen verursachen ; in diesem Fall kann vom Betreiber verlangt werden, angemessene Maßnahmen durchzuführen und dafür aufzukommen.

CE Marking Information

- a) Applicable electromagnetic environment: E4
- b) Peak inrush current: 4.6 A

IMPORTANT SAFETY INSTRUCTIONS

- 1 Read these instructions.
- 2 Keep these instructions.
- 3 Heed all warnings.
- 4 Follow all instructions.
- 5 Do not use this apparatus near water.
- 6 Clean only with dry cloth.
- 7 Do not block any ventilation openings. Install in accordance with the manufacturer's instructions.
- 8 Do not install near any heat sources such as radiators, heat registers, stoves, or other apparatus (including amplifiers) that produce heat.
- 9 Do not defeat the safety purpose of the polarized or grounding-type plug. A polarized plug has two blades with one wider than the other. Grounding type plug has two blades and a third grounding prong. The wide blade or the third prong are provided for your safety. If the provided plug does not fit into your outlet, consult an electrician for replacement of the obsolete outlet.
- 10 Protect the power cord from being walked on or pinched, particularly at plugs, convenience receptacles, and the point where they exit from the apparatus.
- 11 Only use attachments/accessories specified by the manufacturer.
- 12 Use only with the cart, stand, tripod, bracket, or table specified by the manufacturer or sold with the apparatus. When a cart is used, use caution when moving the cart/apparatus combination to avoid injury from tip-over.
- 13 Unplug this apparatus during lightning storms or when unused for long periods of time.
- 14 Refer all servicing to qualified service personnel. Servicing is required when the apparatus has been damaged in any way, such as power-supply cord or plug is damaged, liquid has been spilled or objects have fallen into the apparatus, the apparatus has been exposed to rain or moisture, does not operate normally, or has been dropped.
 - Do not expose this apparatus to drips or splashes.
 - Do not place any objects filled with liquids, such as vases, on the apparatus.
 - Do not install this apparatus in a confined space such as a book case or similar unit.
 - The apparatus draws nominal non-operating power from the AC outlet with its STANDBY/ON in the Standby position.
 - The apparatus should be located close enough to the AC outlet so that you can easily grasp the power cord plug at any time.
 - An apparatus with Class I construction shall be connected to an AC outlet with a protective grounding connection.
 - Batteries (battery pack or batteries installed) should not be exposed to excessive heat such as sunshine, fire or the like.
 - Excessive sound pressure from earphones and head-phones can cause hearing loss.



- 13 Unplug this apparatus during lightning storms or when unused for long periods of time.

SAFETY INFORMATION

This product has been designed and manufactured according to FDA regulations "title 21, CFR, chapter 1, subchapter J, based on the Radiation Control for Health and Safety Act of 1968", and is classified as a class 1 laser product. There is no hazardous invisible laser radiation during operation because invisible laser radiation emitted inside of this product is completely confined in the protective housings. The label required in this regulation is shown at ①.

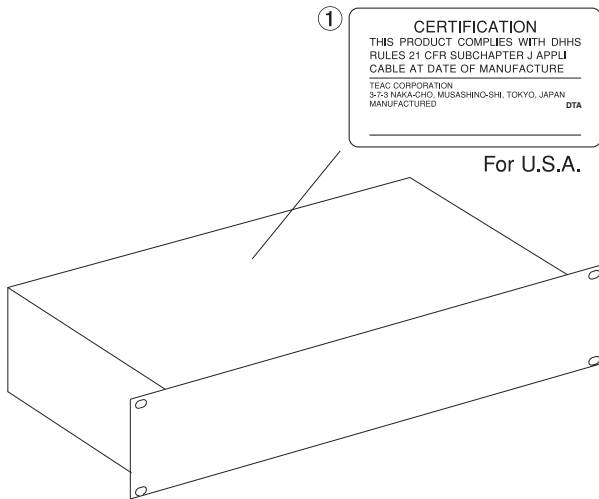

CAUTION

- DO NOT REMOVE THE PROTECTIVE HOUSING USING A SCREWDRIVER.
- USE OF CONTROLS OR ADJUSTMENTS OR PERFORMANCE OF PROCEDURES OTHER THAN THOSE SPECIFIED HEREIN MAY RESULT IN HAZARDOUS RADIATION EXPOSURE.
- IF THIS PRODUCT DEVELOPS TROUBLE, CONTACT YOUR NEAREST QUALIFIED SERVICE PERSONNEL, AND DO NOT USE THE PRODUCT IN ITS DAMAGED STATE.

MD drive optical pickup:

Type: KMS-260E
 Manufacturer: SONY Corporation
 Laser output: 4.55 mW
 Wavelength: 785+/-20 nm

CD drive optical pickup:

Type: SF-P151NVD
 Manufacturer: Sanyo Electric Co.,Ltd.
 Laser output: Less Than 0.2 mW on the objective lens
 Wavelength: 790+10/-15 nm

For China

产品有毒有害物质或元素的名称及含量

机种: MD-CD1MK II		有毒有害物质或元素					
品名	铅 (Pb)	汞 (Hg)	镉 (Cd)	六价铬 (Cr6+)	多溴联苯 (PBB)	多溴二苯醚 (PBDE)	
1 CHASSIS 部份	○	○	○	○	○	○	
2 CD DRIVE UNIT 部份	×	○	○	○	○	○	
3 FRONT PANEL 部份	○	○	○	○	○	○	
4 MD DRIVE UNIT 部份	○	○	○	○	○	○	
5 PCB Assy 部份	×	○	○	○	○	○	
6 电源部份	○	○	○	○	○	○	
7 线材部份	○	○	○	○	○	○	
8 螺丝部份	×	○	○	○	○	○	
9 附属品部份	○	○	○	○	○	○	
10 SEAL 部份	○	○	○	○	○	○	
11 包装部分	○	○	○	○	○	○	

○: 表示该有毒有害物质在该部件所有均质材料中的含量均在 SJ/T11363-2006 标准规定的限量要求以下。

×: 表示该有毒有害物质至少在该部件的某一均质材料中的含量超出 SJ/T11363-2006 标准规定的限量要求。

(针对现在代替技术困难的电子部品及合金中的铅)

Table of Contents

Introduction	
Supplied accessories	6
Environmental considerations	6
Rack-mounting the unit	6
Some notes and precautions	6
Beware of condensation	7
Handling of compact discs	7
Handling of MiniDiscs	8
About the User Table of Contents (U-TOC)	8
Remote control unit	
Some notes and precautions	9
Batteries	9
Inserting batteries	9
Connections	
Audio equipment	10
Connecting analog audio equipment	10
Connecting digital audio equipment	10
Power source	10
Features and their functions	
Front panel	11
Shared features	11
CD Operation	12
MD Operation	13
Display	14
Rear Panel	15
Remote Control Unit	16
Shared operation keys	16
CD Operation Section	18
MD Operation Section	18
Display master and remote control master	
Selecting the remote control master	20
Selecting the display master	20
Menu operation	
Menu configuration	21
Operation basics	23
CD and MD Playback	
Discs for playback	24
Playback modes	24
Basic playback operation	24
Using headphones	25
Display master and remote master settings 25	
Track selection	25
Using the skip function	25
Selecting by track number	25
Search	25
Time Search function	26
Basic operation	26
Operation variations	26
Auto cue	26
Auto Ready	27
Repeat playback	27
A to B repeat playback	27
Continuous CD and MD playback	28
Timer Playback	28
Pitch control	28
Single-track playback	29
Program playback	29
Random playback	30
Time display switching	30
End of disc/track warning	31
Playback functions for CD only	31
Changing the key of playback	31
Fade-in and fade-out	31
Output volume	32
MP3 file directory playback	32
Directory playback setting	32
Setting MP3 ACTION	32
MD group playback	33
Group playback setting	33
Dubbing from CD to MD	
Basic dubbing operation	34
Recording mode setting	34
Dubbing speed setting	34
MD recording from an external source	
Basic recording	35
Recording cautions	36
Adding track numbers	36
Auto track function	36
Entering a track number manually	36
Fade-in and fade-out recording	37
“Time Machine” recording	37
Overwrite recording	38
Sync recording	38
Checking remaining MD time	39
MiniDisc editing	
Editing operations	40
UNDO an edit operation	40
Erase track	40
Erase disc	41
Divide tracks	41
Combine tracks	42
Move tracks	42
Creating a group	43
Deleting a group	43
Title input	
Disc title input	44
Title input operation	44
Track title input	45
Group title input	45
Using a computer keyboard	
Keyboard type setting	46
Title input by keyboard	46
Other keyboard operations	47
Data settings / service data	
Data communication settings	48
Viewing service data	48
Initializing all data	48
System limitations	
CD section	49
About finalization	49
About MP3 track data	49
MD section	50
Message display glossary	
Operation messages	51
Error Messages	51
Troubleshooting	52
Specifications	
MD deck	53
CD deck	53
Rated input/output	53
MD specifications	53
CD specifications	53
Dimensional drawing	54

1 – Introduction

Thank you for your purchase of the TASCAM MD-CD1MKII MiniDisc Deck and CD Player.

Before connecting and using the unit, please take time to read this manual thoroughly to ensure you understand how to properly set up and connect the

MD-CD1MKII, as well as the operation of its many useful and convenient functions. After you have finished reading this manual, please keep it in a safe place for future reference.

Supplied accessories

In addition to this manual, the MD-CD1MKII has been packed with the following:

- RC-MC1 remote control unit
- 2 AA batteries
- Power cord
- Rack-mounting kit
- Warranty document

NOTE

The batteries are not supplied for Taiwan.

Should any of these items be missing, or if you encounter any damage, please contact your TASCAM supplier.

This unit was packed in its carton with special materials in order to prevent any damage during shipment. Please save the carton and packing materials in the event you need to transport the unit in the future.

Environmental considerations

The MD-CD1MKII may be used in most places, but to maintain top performance and prolong operating life, do not place it in the following locations.

- On an unsteady surface, or where there is frequent vibration or resonance
- Near a window or where it can be exposed to direct sunlight
- Near heating or air conditioning vents, or in very hot or cold places
- Places with high humidity or poor ventilation
- Next to tuners, televisions or video decks, as this could cause noise or affect video images

Rack-mounting the unit

Use the rack-mounting kit to mount the unit in a standard 19-inch equipment rack, as shown below. Remove the feet of the unit before mounting. If you are mounting the unit in a rack, leave 1U of space above it.

See “Environmental considerations” on the previous page.

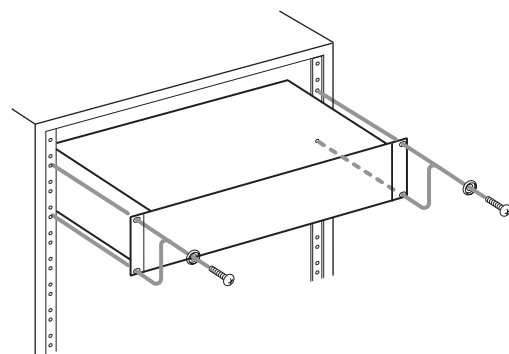

Some notes and precautions

Connect the MD-CD1MKII only to the specified power source. When unplugging the cord, grasp the plug itself.

Clean only with a dry cloth. Do not use benzene, paint thinner or other agents that could damage the surface. Dust or grime on the top cover can be removed with a soft cloth lightly moistened with a diluted mild detergent solution.

Beware of condensation

If the unit is moved from a cold to a warm place, or used after a sudden temperature change, condensation inside the unit may occur, resulting in moisture on the internal mechanism or an inserted disc, thus impairing proper operation. Should this occur, leave

the player turned on for one or two hours so that the condensation can evaporate before you begin operation. Also, please remove all discs from the unit if it will be moved, or not operated for an extended period of time.

Handling of compact discs

The MD-CD1MKII has been designed for the playback of CD-DA format discs and MP3 files recorded in ISO9660 format. In addition to ordinary 5-inch and 3-inch CDs, it can also play properly recorded CD-R and CD-RW discs.

When removing a CD from its case, press down on the center of the disc holder to free the CD, then lift the disc out, holding it carefully by the edges.

- Removing a disc

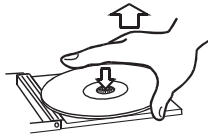

- Hold the CD like this



- Avoid getting fingerprints on the signal side (opposite the label side). When cleaning, wipe gently with a soft cloth from the center towards the outside edge. Dust and grime may cause skipping, so keep discs clean and store them in their cases when not being played.



- Do not use any record spray, anti-static solutions, benzene, paint thinner or other chemical agents to clean CDs as they could damage the delicate playing surface.
- Keep discs away from direct sunlight, and places of high heat and humidity. If left in such places, warping could result.
- Do not affix any labels or stickers to the label side of the disc. Do not write on the disc with a ball-point pen.
- Please do not insert discs that have adhesive remaining from tape or stickers that have been removed. If they are inserted into the player, they could stick to the internal mechanism, requiring removal by a technician.



1 – Introduction—Environmental considerations

Handling of MiniDiscs

The disc itself is mounted inside a cartridge. Should the cartridge become soiled or warped, playback or recording may not be possible. To ensure proper operation, please observe the following.

- After use, always return the MiniDisc to its case.
- Do not open the shutter or touch the disc inside. If the shutter is forced open, the mechanism could easily break.

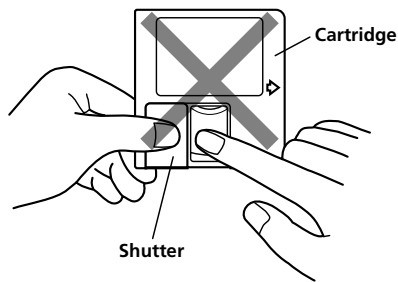

- Keep discs out of direct sunlight and places of high heat and humidity.
- Dirt and grime on the cartridge surface should be wiped away with a dry cloth.
- Loose or raised labels may jam the playback mechanism.
- Do not stick labels over one another on the cartridge.

About the User Table of Contents (U-TOC)

The U-TOC on recordable MiniDiscs makes it easy to edit the tracks on the disc. It contains track information (such as titles and starting and ending addresses), and by rewriting this data, the playback order can be freely changed.

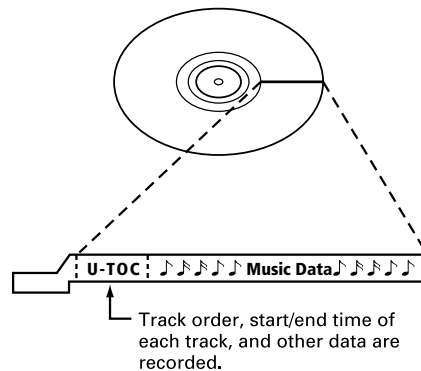

2 – Remote control unit

Some notes and precautions

- When the remote control will not be used for an extended period of time, please remove the batteries to prevent the possibility of battery acid leakage which could damage the unit. Should leakage occur, remove and discard the batteries, and wipe the battery case thoroughly with a cloth. Avoid getting the battery liquid on the skin. After cleaning, replace with new batteries.
- The remote control functions by using an infrared light signal. When using the unit to control the MD-CD1MKII, other devices that are turned on could be operated by its signal.
- If the range of remote operation becomes smaller, or commands do not always function properly, the batteries have become weak and should be replaced. Always replace both batteries with new batteries of the same type.
- Point the remote control to the remote sensor on the main unit.
Do not obstruct the path between the remote control and the remote sensor.

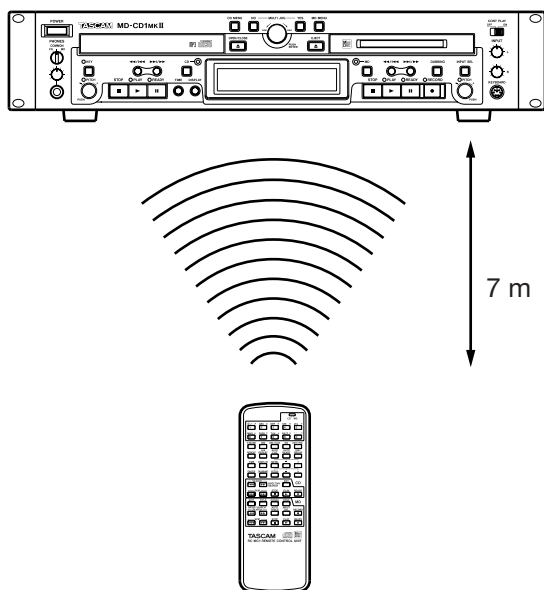

Batteries

If batteries are used improperly, or if leakage or breakage occurs, the unit will not function. Please observe the cautions indicated on the batteries and their packaging to ensure proper usage.

- Confirm + and – polarity and follow the indications when inserting new batteries into the remote control.
- Do not use old and new batteries together.
- Even if the battery is the same size, the voltage may differ. Do not use batteries of different specifications together.
- Do not attempt to recharge batteries that are non-rechargeable.
- Do not open or disassemble batteries, throw them into a fire or put them in water.

NOTE

The batteries are not supplied for Taiwan.

Inserting batteries

1. Open the lid.
2. Confirm +/- polarity, and insert two AA batteries.
3. Close the lid.

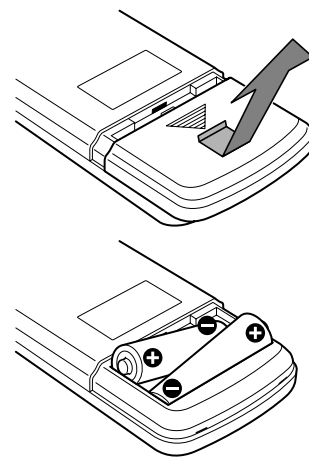

3 – Connections

Before connecting the MD-CD1MKII to other units, please read their operation manuals thoroughly to ensure proper connection. Turn the power on only after all connections have been made.

Audio equipment

Connecting analog audio equipment

Connect analog stereo amplifiers, mixers and recorders to the analog line inputs and outputs. There are input terminals for the MD deck recording source and terminals for both the CD and MD outputs, as well as a COMMON output for the output signals of the CD deck, the MD deck, or both. Selection of either or both deck's output signals can be performed on the SYSTEM sub-menu of the CD menu under the "COMMON?" option.

NOTE

- The optional LA-MC1 Balanced Analog Input/Output Board can be installed to enable the MD-CD1MKII to be used in a balanced system.
- Connection cables are not supplied with this unit.
- Do not bundle the pin connection cords with the power cord as noise or diminished sound quality could result.

Connecting digital audio equipment

Digital stereo amplifiers, mixers and recorders can be connected through the optical digital input/output terminals.

NOTE

The MD-CD1MKII features a sampling rate converter, which enables you to digitally record signals not only at a sampling rate of 44.1 kHz (a sampling rate for MD), but also at sampling rates of 32 kHz or 48 kHz.

Power source

This unit has been designed to operate on the specified power voltage only. Do not plug the power cord into outlets of any other voltage.

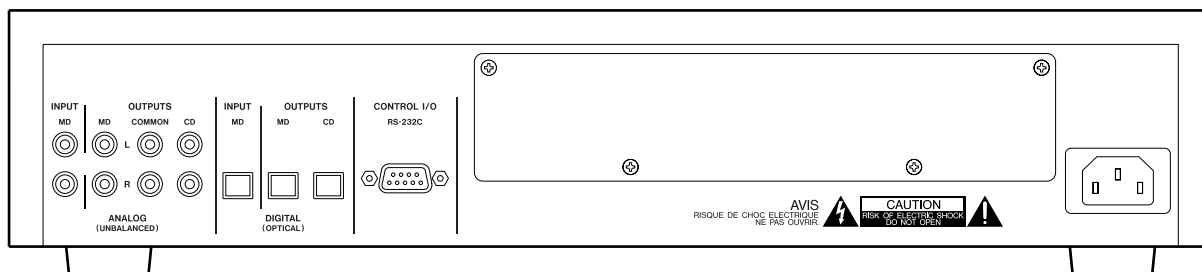

4 – Features and their functions

Front panel

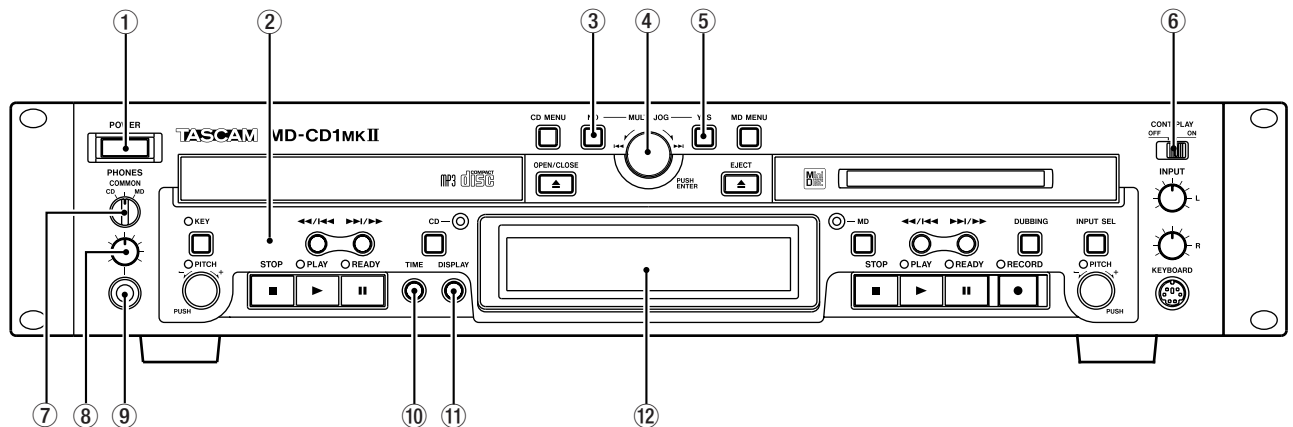

Shared features

① Power switch

② Remote signal sensor

③ **NO key** Used to cancel menu operations during menu mode.

During title input mode, it is used to delete character inputs

④ **MULTI JOG dial / ENTER key** Functions as the MULTI JOG dial when rotated, and as the ENTER key when pushed

MULTI JOG dial functions

Normal mode: selection of MD disc groups (when MD indicator is lit and group mode is ON) or selection of MP3 disc directories (when CD indicator is lit)

Program mode: selection of recorded tracks

Menu mode: selection of menu options and their settings

MD Edit mode: selection of editing points

Title input mode: character input selection

In any mode other than those listed above, the dial performs the display master deck's Track Skip function.

ENTER Key functions

Program mode: confirmation of selected tracks

Menu mode: confirmation of menu options and confirmation of settings and editing on the menu (works the same as the YES key)

Title input mode: confirmation of selected characters

⑤ **Yes key** Menu mode: confirmation of menu options and confirmation of settings and editing on the menu

Title input mode: inserts characters

⑥ **CONT PLAY switch** When ON, the CD and MD decks play successively. During playback, the deck automatically becomes the display master.

⑦ PHONES source selection switch

During headphone monitoring, CD, COMMON or MD can be selected as the source. When COMMON is selected, both CD and MD sources can be simultaneously monitored. When both decks output a signal, the monitored source depends on the "COMMON?" option setting on the SYSTEM menu.

⑧ **PHONES level control** Adjusts the headphone output level

⑨ **PHONES jack** This is a standard pin jack for stereo headphone connection. When using headphones with a stereo mini plug, an adaptor is required.

⑩ **TIME key** Pressing this key changes the time mode on the display. Refer to "Time display switching" on page 30. Even when the power is turned off, the time mode is retained.

⑪ **Display key** Used to select input character type during Title Input mode. Refer to "Title input" on page 44.

The type of character selected is indicated by the display.

Lower case letters/code: no indication

Capital letters/code: CAPS

Japanese: カタカナ

⑫ **Display** CD and MD data, deck operation mode, menus and other information are shown on the display. For details, refer to "Display" on page 14.

4 – Features and their functions—Front panel

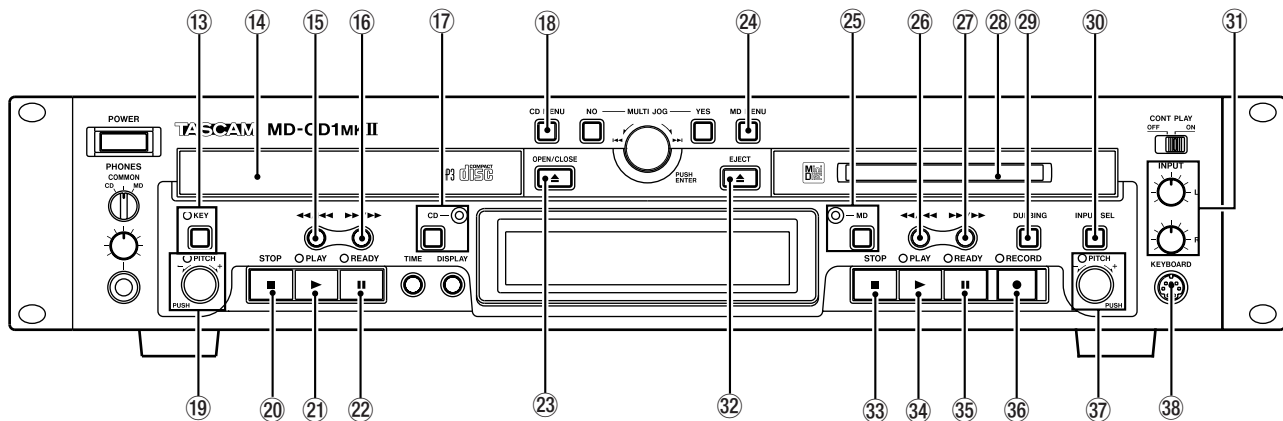

CD Operation

13 KEY key / Indicator When this key is pressed, the Indicator light goes on and the Key Change function is turned on, allowing you to change the musical key of Compact Disc playback. Refer to “Changing the key of playback” on page 31. Even when the power is turned off, the key change setting is retained.

14 CD Tray Compact Discs are placed here for loading.

15 <</I key In normal mode, this key is used to skip back a track or for review playback (search). When playback is stopped, if this key is pressed once, the previous track is selected; if it is pressed continuously, the tracks are skipped backward at high speed.

During playback, if this key is pressed once, the beginning of the current track is cued, and playback restarts; if it is pressed continuously, review playback (search) is performed.

16 >>/I key In normal mode, this key is used to skip forward a track or for cue playback (search). When playback is stopped, if this key is pressed once, the next track is selected; if it is pressed continuously, the tracks are skipped forward at high speed.

During playback, if this key is pressed once, the beginning of the next track is cued, and playback begins; if it is pressed continuously, cue playback (search) is performed.

17 CD key / indicator When this key is pressed, the indicator goes on, CD becomes the display master, and CD deck and disc information (such as settings and time) are shown on the display. Even when the power is turned off, the display master setting is retained.

18 CD Menu key This turns the CD Menu mode on or off. In CD Menu mode, the CD indicator light flashes, CD menu options are indicated on the display, and settings can be performed.

NOTE

If the CD Menu key is pressed when the display master is MD, the MD indicator stays lit, while the CD indicator flashes.

If the CD Menu key is pressed when the display master is CD (CD indicator ON), the CD indicator will begin flashing.

19 PITCH Control / Indicator Push this control to turn the pitch control function on or off. When it is on, the indicator lights up, and pitch can be controlled +16% to -50%. Even when the power is turned off, the pitch control ON/OFF setting is retained.

20 STOP key During CD playback, press this key to stop playback. When this key is pressed during dubbing operation, both the MD and CD decks stop simultaneously.

21 PLAY key Press this key to start CD playback. When this key is pressed during dubbing standby mode, the CD deck starts playback, the MD deck starts recording, and dubbing begins.

22 READY (II) key When this key is pressed during playback or while stopped, the CD deck enters standby mode.

23 OPEN/CLOSE (▲) key Press this key to open or close the CD tray.

MD Operation

②④ **MD Menu key** This turns the MD Menu mode on or off. In MD Menu mode, the MD indicator flashes, MD Menu options are indicated on the display, and settings can be performed.

NOTE

If the MD Menu key is pressed when the display master is CD, the CD indicator stays lit, while the MD indicator flashes.

If the MD Menu key is pressed when the display master is MD (MD indicator ON), the MD indicator will begin flashing.

②⑤ **MD key / indicator** When this key is pressed, the indicator goes on, MD becomes the display master, and MD deck and disc information (such as settings and time) are shown on the display. Even when the power is turned off, the display master setting is retained.

②⑥ **◀◀/▶▶ key** In normal mode, this key is used to skip back a track or for review playback (search). When playback is stopped, if this key is pressed once, the previous track is selected; if it is pressed continuously, the tracks are skipped backward at high speed.

During playback, if this key is pressed once, the beginning of the current track is cued, and playback restarts; if it is pressed continuously, review playback (search) is performed.

During Title Input mode, this key is used to move the cursor to the left.

②⑦ **▶▶/▶▶ key** In normal mode, this key is used to skip forward a track or for cue playback (search). When playback is stopped, if this key is pressed once, the next track is selected; if it is pressed continuously, the tracks are skipped forward at high speed.

During playback, if this key is pressed once, the beginning of the next track is cued, and playback begins; if it is pressed continuously, cue playback (search) is performed.

During Title Input mode, this key is used to move the cursor to the right.

②⑧ **MD slot** Insert a MiniDisc here for playback or recording. With the label side up, insert in the direction of the arrow.

②⑨ **DUBBING key** This is used when dubbing from CD to MD. For details, see “Dubbing from CD to MD” on page 34.

③⑩ **INPUT SEL key** This key is used to select the recording input source for the MD deck. The key switches between ANALOG and DIGITAL. During Dubbing mode, the CD output signal is automatically

selected as the source. Even when the power is turned off, the input source selection is retained.

③① **INPUT (L / R) controls** These controls are used to adjust the input level when recording analog signals to MD. The left and right channels may be independently controlled.

③② **EJECT (▲) key** Press this to eject the MiniDisc.

③③ **STOP (■) key** Press this key to stop MD playback or recording.

If this key is pressed during dubbing, the MD deck and the CD player stop simultaneously.

During MD Editing mode, when this key is pressed, the Editing mode is cancelled, and the deck returns to Normal mode.

③④ **PLAY (▶) key** Press this key to start playback when the MD deck is in stop or standby mode.

When this key is pressed during dubbing standby mode, the CD deck begins playback and the MD deck begins recording, and dubbing begins.

③⑤ **READY (⏏) key** When this key is pressed during MD playback or while stopped, the MD deck enters standby mode.

When this key is pressed during MD recording, the MD deck enters recording standby mode.

③⑥ **RECORD (●) key** When this key is pressed and there is no MiniDisc in the mechanism, the input signal can be monitored.

If a recordable MiniDisc is inserted into the mechanism while it is stopped, when this key is pressed, the MD deck enters recording standby mode, and the input signal can be monitored.

When this key is pressed during recording, a track mark is entered at that point and a new track is started.

③⑦ **PITCH control / Indicator** Push this control to turn the pitch control function on or off. When it is on, the indicator lights up, and pitch can be controlled +/- 12.5%. During ON mode, signals cannot be output from the digital output terminals [DIGITAL (OPTICAL) – OUTPUTS – MD terminals]. Even when the power is turned off, the pitch control ON/OFF setting is retained.

③⑧ **KEYBOARD connector** An IBM PC-compatible keyboard with PS/2 interface can be connected to this terminal to enable certain operations of the MD-CD1MKII with the keyboard. Title input operations, in particular, can be performed with greater efficiency.

4 – Features and their functions—Display

Display

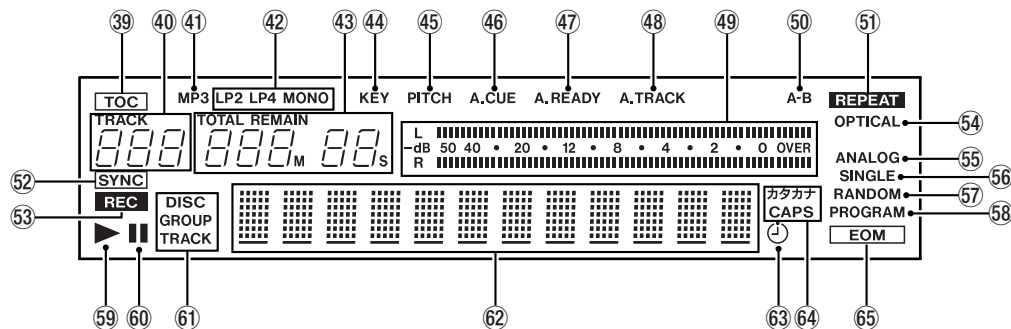

This display shows various types of operation information, including CD and MD disc information, deck operation modes, and menu status. Disc and deck information for either CD and MD are shown by pressing either the CD key or the MD key, and the deck selected becomes the display master. Also, the CD Menu key or the MD Menu key can be pressed to call up the CD Menu or the MD Menu.

- 39 **TOC** When the most recent TOC (Table of Contents) data has not been recorded, this lights up red. During TOC recording, the indicator flashes.
- 40 **Track number display** During playback or selection, the track number is displayed.
- 41 **MP3** This indicator is lit when and MP3 disc is in the CD deck.
- 42 **MD recording mode display (LP2, LP4, MONO)** This indicates the recording mode of the MiniDisc. If the disc was recorded in Normal mode, it does not light up.
- 43 **Counter display** Depending on the time display mode, TOTAL or REMAIN are lit. Counter display indication is in minutes (three digits) and seconds (two digits).
- 44 **KEY** This lights when the CD deck's Key Change function is on.
- 45 **PITCH** This lights when the display master deck's Pitch Control function is on.
- 46 **A. CUE** This lights when the display master deck's Auto Cue function is on.
- 47 **A. READY** This lights when the display master deck's Auto Ready function is on.
- 48 **A. TRACK** This lights when the display master deck's Auto Track function is on. It flashes during recording, in recording standby mode, or when the Track function is set to "Time."

- 49 **Meter** This displays the playback level or either the CD or MD deck, as well as the recording level of the MD deck.
- 50 **A-B** This lights when the display master deck's A-B Repeat function is on.
- 51 **REPEAT** This lights when the display master deck's Repeat function is on.
- 52 **SYNC** This lights during SYNC recording mode.
- 53 **REC** This lights when the MD deck is recording, or in recording standby mode.
- 54 **OPTICAL** This lights when the MD input source is set to digital.
- 55 **ANALOG** This lights when the MD input source is set to analog.
- 56 **SINGLE** This lights when the display master deck is in single playback mode.
- 57 **RANDOM** This lights when the display master deck is in random playback mode.
- 58 **PROGRAM** This lights when the display master deck is in program playback mode.
- 59 **▶** This lights when the display master deck is in playback or recording mode. Also, when the Auto Cue function is on, it flashes during Auto Cue point search.
- 60 **||** This lights when the display master deck is in recording or playback standby mode.
- 61 **DISC, GROUP, TRACK display** DISC lights up when the display master deck has a disc loaded and is stopped. GROUP lights up when the display master is the CD deck and the Directory mode is on, or when the display master is the MD deck and the group mode is on.

4 – Features and their functions—Rear Panel

TRACK is indicated during playback or playback standby.

⑥2 **Character display** Disc information, track information, menu, message and operation status are displayed.

⑥3  This lights when the Timer Play function is on.

It flashes if a disc is not loaded when the Timer Play function is on.

⑥4 **CAPS, カタカナ** These light during title input to indicate either CAPS or Japanese character mode. In lower case letter mode, there is no indication.

⑥5 **EOM** This lights when the remaining track/disc time is less than the EOM set value.

Rear Panel

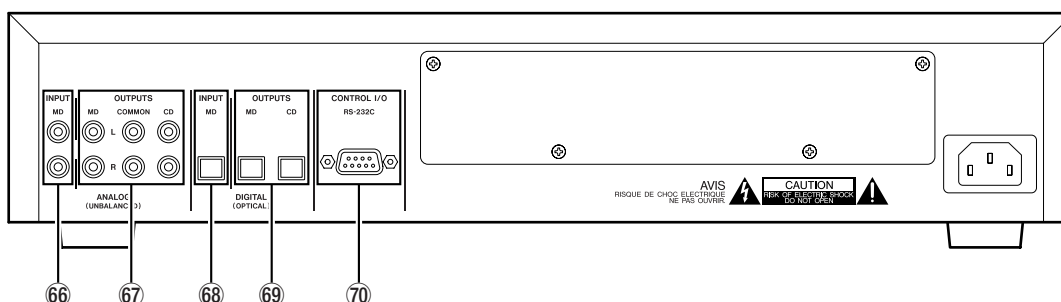

⑥6 **ANALOG INPUT MD Terminals** The analog line input terminals for the MD deck are for RCA pin jacks. Rated input level is -10 dBV.

⑥7 **ANALOG OUTPUTS – CD – COMMON – MD Terminals** The analog line output terminals are for RCA pin jacks. Rated output level is -10 dBV.

CD: Outputs the CD deck signal.

COMMON: Outputs CD and MD signals. During playback of both decks, the output signal depends on the “COMMON?” option setting on the SYSTEM menu.

MD: Outputs the MD deck signal. During playback, the playback signal is output; during input monitoring, the source signal is output.

⑥8 **DIGITAL (OPTICAL) INPUT Terminal** This is the digital input terminal for the MD deck.

⑥9 **DIGITAL (OPTICAL) OUTPUTS – MD – CD Terminals** These are the digital output terminals (optical). The playback signals from the MD deck and the CD deck are output through their respective digital output terminals.

⑦0 **CONTROL I/O (RS-232C) Connector** RS-232C compatible serial control from an external PC can be performed.

Remote Control Unit

Shared operation keys

MD operation keys / CD operation keys

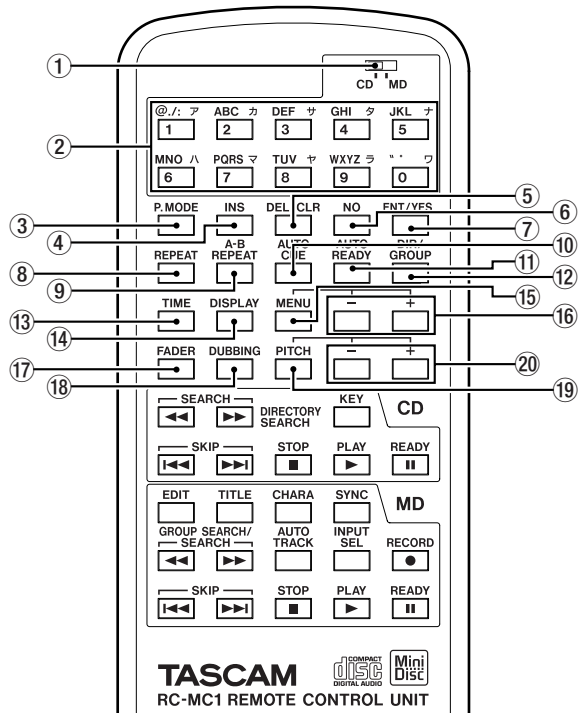

Shared operation keys

The ① key is used to select CD or MD deck operation, while keys ② and beyond are shared operation keys.

① **CD/MD selector** Selects the remote control master. Refer to “Display master and remote master settings” on page 25. The following shared operation keys operate the functions of the remote control master deck (CD or MD selectable).

② **Number keys (0 – 9)** These are used to select track numbers and for time search. During MD Title Input mode, they can be used to input letters, codes, numbers and Japanese characters. Characters that can be input are indicated on the keys.

NOTE

Track number selection and time search can only be performed for the display master deck. These functions cannot be operated for the deck selected as the remote control master.

NOTE

While these keys can also be used for character input during title input operation, in this manual they are referred to as “Number keys.”

③ **P. MODE key** This selects the playback mode. During selection, the playback mode is indicated on the display in the following manner.

Normal playback (in disc order): no indication

Single playback: SINGLE lights up

Program playback: PROGRAM lights up

Random playback: RANDOM lights up

For the modes apart from normal playback, please refer to “Single-track playback” on page 29, “Program playback” on page 29 and “Random playback” on page 30.

Even when the power is turned off, the playback mode setting is retained.

④ **INS key** During MD Title Input mode, this key inserts a space at the cursor position.

⑤ **DEL/CLR key** During track number input, the track number is cleared when this key is pressed.

During program input, the selected program number track is deleted.

During title input, the character at the cursor position is deleted.

⑥ **NO key** This operates the same way as the NO key on the unit.

⑦ **ENT/YES key** This operates the same way as the YES and ENTER keys on the unit.

⑧ **REPEAT key** This turns the Repeat Mode on and off. When it is on, REPEAT lights up in the display. Refer to “Repeat playback” on page 27. Even when the power is turned off, the Repeat Mode setting is retained.

⑨ **A-B REPEAT key** This turns the A-B Repeat Mode on and off, and is used to set the section for repeat playback. Refer to “A to B repeat playback” on page 27.

⑩ **AUTO CUE key** This turns the Auto Cue Mode on and off. When it is on, A CUE lights up in the display. Refer to “Auto cue” on page 26. Even when the power is turned off, the Auto Cue Mode setting is retained.

4 – Features and their functions—Remote Control Unit

⑪ **AUTO READY key** This turns the Auto Ready Mode on and off. When it is on, A READY lights up in the display. Refer to “Auto ready (of a specified track)” on page 27. Even when the power is turned off, the Repeat mode setting is retained.

⑫ **DIR/GROUP key** When this key is pressed during stop, it turns on or off the MP3 disc directory playback mode (when the CD deck is the remote control master) or the MD group playback mode (when the MD deck is the remote control master).

Refer to “MP3 file directory playback” on page 32, and “MD group playback” on page 33.

⑬ **TIME key** This operates in the same way as the TIME key on the unit.

⑭ **DISPLAY key** When pressed during stop mode, the current disc title is displayed.

When pressed during playback or playback standby mode, the current track title is displayed. Also, if the CD/MD Selector is set to the side which is not the current display master, pressing the DISPLAY key will change the current display master setting.

⑮ **MENU key** This key is used to turn on and off the Menu of the current remote control master deck. It operates in the same way as the CD MENU and MD MENU keys on the unit.

⑯ **MENU +/- key** During Menu Mode, this key is used to select menu options and make settings. It operates in the same way as the MULTI JOG dial on the unit. However, you cannot select a track.

⑰ **FADER key** When pressed during CD playback standby, the sound will fade in when playback resumes. When pressed during CD playback, the sound will fade out.

When pressed during MD recording standby, the sound will fade in when recording begins. When pressed during MD recording, the recorded sound will fade out.

⑱ **DUBBING key** This operates in the same way as the DUBBING key on the unit. Refer to “Dubbing from CD to MD” on page 34.

⑲ **PITCH key** This operates in the same way as pressing the PITCH key/dial on the MD and CD operation sections of the unit, and is used to turn the pitch control on and off. Refer to “Pitch control” on page 28. Even when the power is turned off, the pitch control on/off setting is retained.

⑳ **PITCH +/- key** This operates in the same way as when rotating the PITCH key/dial on the MD and CD operation sections of the unit. When pitch control is on, the pitch value can be set. Refer to “Pitch control” on page 28. Even when the power is turned off, the pitch setting is retained.

CD Operation Section

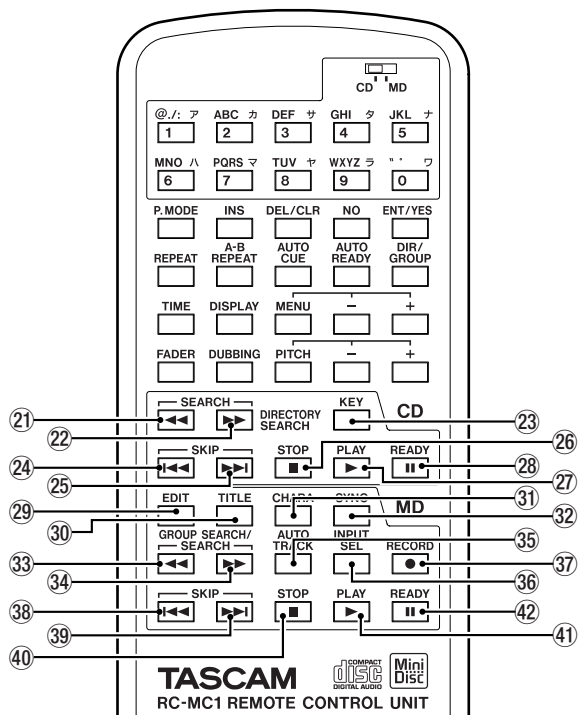

21 ◀◀ **key** During playback or playback standby, press this key continuously for review playback (search).

When an MP3 disc is in the deck during stop mode, if this key is pressed, the directory can be chosen (backward direction).

22 ▶▶ **key** During playback or playback standby, press this key continuously for cue playback (search).

When an MP3 disc is in the deck during stop mode, if this key is pressed, the directory can be chosen (forward direction).

23 **KEY key** This turns the Key Change function on and off. When it is on, the musical key of CD playback can be changed. Key change settings can be performed from the CD menu. Refer to “Changing the key of playback” on page 31. Even when the power is turned off, the key change settings are retained.

24 ◀◀◀ **key** During normal playback, use this key to skip through tracks in the reverse direction for selection. During stop mode, press this key to skip through tracks backwards, or press it continuously to skip at high speed. During playback, press this key to skip back to the start of the track in play.

25 ▶▶▶ **key** During normal playback, use this key to skip through tracks in the forward direction for selection. During stop mode, press this key to skip through tracks forwards, or press it continuously to skip at high speed. During playback, press this key to skip to the start of the next track.

26 **STOP (■) key** Operation is the same as with the STOP key on the CD operation section of the unit.

27 **PLAY (▶) key** Operation is the same as with the PLAY key on the CD operation section of the unit.

28 **READY (||) key** Operation is the same as with the READY key on the CD operation section of the unit.

MD Operation Section

29 **EDIT key** During normal operation, Menu mode and Title Input mode, press this key to enter MD Edit mode. Refer to “MiniDisc editing” on page 40.

When this key is pressed during MD Edit mode, the unit returns to normal operation mode.

30 **TITLE key** During normal operation, Menu mode and MD Edit mode, press this key to enter Title Input mode. Refer to “Title input” on page 44.

When this key is pressed during Title Input mode, the unit returns to normal operation mode.

31 **CHARA key** During Title Input mode, press this key to switch between types of input characters. Refer to “Title input” on page 44.

The type of character selected is indicated by the display.

Lower case letters/code: no indication

Capital letters/code: CAPS

Japanese: カタカナ

32 **SYNC key** This key is used to turn SYNC recording on or off. When on, recording is automatically started and stopped depending upon the input signal level. Refer to “Sync recording” on page 38.

When on, the SYNC indicator in the display lights up.

33 ◀◀ **key** During playback or playback standby, press this key continuously for review playback (search).

When Group mode is on during stop mode, if this key is pressed, groups can be chosen (backward direction).

4 – Features and their functions—Remote Control Unit

③④ **▶▶ key** During playback or playback standby, press this key continuously for cue playback (search).

When Group mode is on during stop mode, if this key is pressed, groups can be chosen (forward direction).

③⑤ **AUTO TRACK key** During MD recording, this is used to set the Auto Track function. OFF, -**dB DD, or Time can be selected. Refer to “Adding track numbers” on page 36.

Even when the power is turned off, the settings are retained.

③⑥ **INPUT SEL key** Operation is the same as with the INPUT SELECT key on the unit, and is used to choose the MD input source. This key always functions, regardless of the remote control master setting. Refer to “Input source selection” on page 35.

③⑦ **RECORD (●) key** Operation is the same as with the RECORD key on the MD operation section of the unit.

③⑧ **◀◀ key** During normal playback, use this key to skip through tracks in the reverse direction for selection. During stop mode, press this key to skip through tracks backwards, or press it continuously to skip at high speed. During playback, press this key to skip back to the start of the track in play.

During title input mode, press this key to move the cursor in the left direction.

③⑨ **▶▶I key** During normal playback, use this key to skip through tracks in the forward direction for selection. During stop mode, press this key to skip through tracks forwards, or press it continuously to skip at high speed. During playback, press this key to skip to the start of the next track.

During title input mode, press this key to move the cursor in the right direction.

④⑩ **STOP (■) key** Operation is the same as with the STOP key on the MD operation section of the unit.

④⑪ **PLAY (▶) key** Operation is the same as with the PLAY key on the MD operation section of the unit.

④⑫ **READY (||) key** Operation is the same as with the READY key on the MD operation section of the unit.

5 – Display master and remote control master

The MD-CD1MKII is equipped with a CD deck and an MD deck. Since the display and remote control keys can be used by either deck, this function determines which deck is represented by their operation. In this manual, the deck represented by the information in the display is referred to as the “display master,” while the deck being operated by the shared keys on the remote control unit is referred to as the “remote control master.”

Selecting the remote control master

On the upper part of the remote control, there is a CD/MD switch used to select the remote control master. The shared keys on the upper portion of the remote control unit operate for the deck selected as the remote control master.

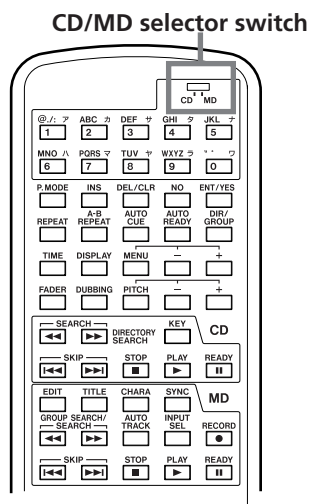

Selecting the display master

The display master can be selected using the CD or MD keys. The CD or MD indicator lights up to show the selection.

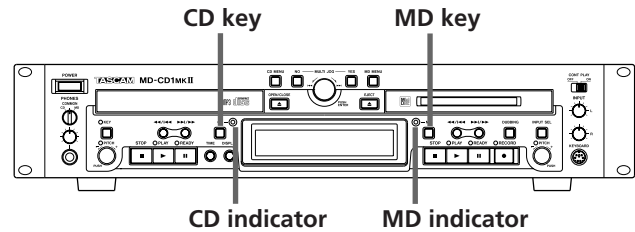

To switch the display master using the remote control, set the CD/MD selector to the desired position, then press the DISPLAY key.

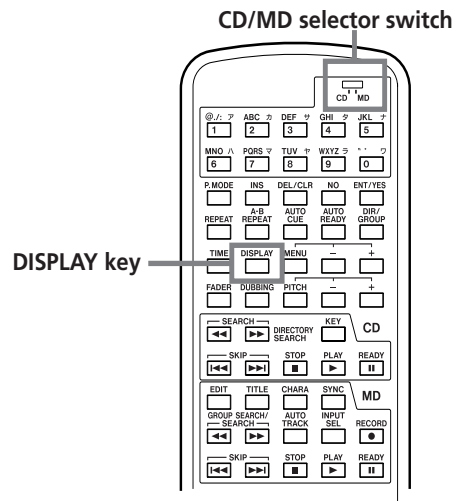

NOTE

When using the shared keys on the remote control unit for operation, if the remote control master deck and the display master deck are not the same, the results of the operation will not be indicated on the display. To confirm operation results, the remote control master deck and the display master deck must be the same.

6 – Menu operation

The various settings and editing operations possible with the MD-CD1MKII are performed through menu options shown on the display. Among the many menu

setting options, some may be made directly using the keys on the remote control.

Menu configuration

There are menus for both CD and MD operation. Below each menu are sub-menus, and in each sub-

menu there are menu options. The menus are configured as shown below.

CD Menu			
Menu option	Function	Manual reference	Page
CD PLAY sub-menu	Options for CD playback		
PLAY MODE	Playback mode settings	"Playback modes"	24
REPEAT	Repeat mode settings	"Repeat playback"	27
A_CUE LEVEL	Auto Cue level setting	"Auto cue"	26
A_CUE	Auto Cue on/off	"Auto cue"	26
A_READY	Auto Ready on/off	"Auto ready (of a specified track)"	27
PITCH STEP	Pitch control variable pitch setting	"Pitch control"	28
EOM TRK	Track EOM mode and operation time	"End of disc/track warning"	31
EOM DISC	Disc EOM mode and operation time	"End of disc/track warning"	31
TIMER PLAY	Timer play on/off	"Timer playback"	28
KEY LEVEL	Key control level setting	"Changing the key of playback"	31
DIR MODE	MP3 disc directory mode on/off	"MP3 file directory playback"	32
MP3 ACTION	Setting the error handling during MP3 file playback	"Setting MP3 ACTION"	32
CD VOL FUNC sub-menu	(CD volume function options)		
PLAY VOLUME	Output level setting	"Output volume"	32
FADE IN	Fade-in operation time setting	"Fade-in and fade-out"	31
FADE OUT	Fade-out operation time setting	"Fade-in and fade-out"	31
FADE MODE	Setting operation mode after fade-out end	"Fade-in and fade-out"	31
SERIAL sub-menu	RS-232C data communication options		
BAUD RATE	data transmission speed setting	"Data settings/service data"	48
LENGTH	data word length setting	"Data settings/service data"	48
PARITY	data parity bit setting	"Data settings/service data"	48
STOP BIT	data stop bit setting	"Data settings/service data"	48
SYSTEM sub-menu	(options for the unit)		
KEYBOARD	setting for keyboard type	"Keyboard type setting"	46
COMMON	CD/MD priority for COMMON output	"Basic playback operation"	24
CD P_TIME	Confirming total CD playing time	"Data settings/service data"	48
MD P_TIME	Confirming total MD playing time	"Data settings/service data"	48
MD R_TIME	Confirming total MD recording time	"Data settings/service data"	48

6 – Menu operation—Menu configuration

IR REMOTE	Disabling or enabling remote control (RC-MC1) operation	“Basic menu operation”	23
F_PRESET	Resetting all data to initial default settings	“Viewing service data”	48
MD Menu			
Menu option	Function	Manual reference	Page
MD PLAY sub-menu	Options for MD playback		
PLAY MODE	Playback mode settings	“Playback modes”	24
REPEAT	Repeat mode settings	“Repeat playback”	27
A_CUE LEVEL	Auto Cue level setting	“Auto cue”	26
A_CUE	Auto Cue on/off	“Auto cue”	26
A_READY	Auto Ready on/off	“Auto ready (of a specified track)”	27
PITCH STEP	Pitch control variable pitch setting	“Pitch control”	28
EOM TRK	Track EOM mode and operation time	“End of disc/track warning”	31
EOM DISC	Disc EOM mode and operation time	“End of disc/track warning”	31
TIMER PLAY	Timer play on/off	“Timer playback”	28
GRP MODE	Group mode on/off	“MD group playback”	33
MD VOL FUNC sub-menu	(MD volume function options)		
REC VOLUME	Input level setting	“Basic recording”	35
FADE IN	Fade-in operation time setting	“Fade-in and fade-out recording”	37
FADE OUT	Fade-out operation time setting	“Fade-in and fade-out recording”	37
FADE MODE	Setting operation mode after fade-out end	“Fade-in and fade-out recording”	37
REC sub-menu	(options for MD recording status)		
REC MODE	Recording mode setting	“Basic recording”	35
REC SPEED	Setting dubbing mode speed	“Basic recording”	35
SYNC LEVEL	Operation level of Sync recording	“Sync recording”	38
SYNC	Sync recording mode on/off	“Sync recording”	38
A_TRK TIME	Setting the time track increment	“Adding track numbers”	36
A_TRK LEVEL	Auto track operation level	“Adding track numbers”	36
A_TRK	Auto track mode	“Adding track numbers”	36
TM_REC	“Time Machine” recording time	“Time Machine recording”	37
EDIT sub-menu	(options for MD editing functions)		
DIVIDE	Dividing tracks	“Divide tracks”	41
COMBINE	Combining tracks	“Combine tracks”	42
MOVE	Moving tracks	“Move tracks”	42
GRP CREATE	Creating groups	“Creating a group”	43
GRP CANCEL	Eliminating a group	“Deleting a group”	43
ERASE DISC	Erasing disc content	“Erase disc”	41
ERASE TRK	Erasing a track	“Erase track”	40

UNDO	Undoing an editing operation	“MiniDisc editing”	40
TITLE sub-menu	(options for MD title editing functions)		
TITLE INPUT	Input of track or disc title	“Title input”	44
TITLE GRP	Input of a group title	“Group title input”	45

Operation basics

1 Select CD Menu or MD Menu

Front panel operation:

Press the CD MENU key or the MD MENU key to call up the desired menu.

Remote control operation:

Press the MENU key and either the CD Menu or the MD Menu is called up, depending upon the position of the CD/MD selector switch.

The sub-menu screen appears.

```
CD PLAY?
```

NOTE

In Menu mode, the CD or MD indicators flash to indicate which menu is called up.

When a menu is chosen for a deck that is not the display master, the display master indicator will remain lit, while the indicator for the menu mode deck will begin flashing. If the menu for the display master deck is selected, its indicator will begin flashing.

2 Select the desired sub-menu

Front panel operation:

Use the MULTI JOG dial to select, then press the ENTER key or the YES key.

Remote control operation:

Use the MENU +/- key to select, then press the ENT/YES key.

The screen for the selected menu option will be displayed.

```
PLAY MODE?
```

NOTE

To return to the sub-menu selection screen from a menu option selection screen, press the NO key on either the front panel or the remote control unit.

3 Select the desired menu option.

Front panel operation:

Use the MULTI JOG dial to select, then press the ENTER key.

Remote control operation:

Use the MENU +/- key to select, then press the ENT/YES key.

The setting screen will be displayed.

```
Mode>Cont
```

NOTE

To return to the menu option selection screen, press the NO key on either the front panel or the remote control unit. However, if the NO key is pressed for an EDIT menu option, you will exit the Menu mode.

4 Settings

Front panel operation:

Use the MULTI JOG dial to select, then press the ENTER key.

Remote control operation:

Use the MENU +/- key to select, then press the ENT/YES key.

NOTE

Some menu options exist for confirmation purposes only, and setting cannot be performed.

For MD Editing Menu operation, refer to “MiniDisc editing” on page 40.

For Title Menu operation, refer to “Title input” on page 44.

5 How to exit Menu mode after setting (or confirmation), during menu option display.

Front panel operation:

Press the CD MENU or MD MENU key corresponding to the current Menu mode.

Remote control operation:

Press the MENU key.

The CD or MD indicator will stop flashing.

NOTE

The “IR REMOTE?” option on the SYSTEM sub-menu of the CD menu enables you to set the unit so that it will not respond to remote control key operations (excluding certain keys).

Set the option to “Enable” so that the unit will respond to all remote control key operations.

7 – CD and MD Playback

The MD-CD1MKII can play both CDs and MDs. Basic playback and the operation of most playback functions are virtually identical for the CD and MD decks. This section will explain the shared playback

functions first, followed by playback functions for CD only, MP3 disc directory playback, and MD group playback.

Discs for playback

The CD and MD decks in the MD-CD1MKII can play back the types of discs listed below.

CD deck

Ordinary audio CDs available commercially (recorded in CD-DA format)

CD-R and CD-RW discs recorded in CD-DA format, and properly finalized

MP3 files recorded in ISO9660 format on CD-R and CD-RW discs, and properly finalized.

MD deck

Audio MiniDiscs recorded in standard, LP2, LP4 and mono modes.

Playback modes

There are four different playback modes for both the CD deck and the MD deck. The mode selected is indicated on the display.

Normal (continuous) playback mode: no indication lamp

Single playback mode: SINGLE is lit

Program playback mode: PROGRAM red lamp is lit

Random playback mode: RANDOM red lamp is lit

The playback mode can be selected using the P.MODE key on the remote control. Pressing the key changes the playback mode in the following order:

Cont → Single → Program → Random

You can also select the playback mode using the “PLAY MODE?” option in the PLAY sub-menu of the CD and MD menus.

While the mode can be changed from any playback mode, the explanation in this manual will assume the user is starting from the normal Continuous mode.

Basic playback operation

1 Push the POWER switch to turn on the unit. The display will indicate NO DISC.

2 Insert a disc.

CD:

2-1 Press the OPEN/CLOSE key, and the CD tray opens.

2-2 Place the CD in the tray, label side up.

2-3 Press the OPEN/CLOSE key again, and the CD tray closes.

NOTE

For 2-3, instead of the OPEN/CLOSE key, if the PLAY key is pressed, the CD tray will close and playback will begin, and if the READY key is pressed, the CD tray will close and the unit will enter playback standby mode.

After a disc is inserted, the total playing time and number of tracks will be displayed.

MD:

2-1 Insert the MiniDisc into the MD slot, in the direction of the arrow, and with the label side up.

After a disc is inserted, the disc title (if there is one), and the total playing time and number of tracks will be displayed.

3 Press the PLAY key.

The ► indication will light up, and playback begins from track 1. The number of the current track in play is indicated on the display.

To stop playback, press the STOP key.

To pause playback, press the READY key.

The || indication will light up, and the unit will enter playback standby mode. To resume playback, press the PLAY key.

7 – CD and MD Playback—Display master and remote master set-

To remove the disc

For a CD, press the OPEN/CLOSE key.

For an MD, press the EJECT key.

To play a desired track

Front panel operation:

press either the ◀◀ or ▶▶ key to select the desired track.

Remote control operation:

use either the ◀◀ or ▶▶ keys, or the numeral keys, to select the desired track.

Refer to “Track selection” on page 25.

Using headphones

Plug the headphone cord into the PHONES jack located under the POWER switch. Use the source selector switch to choose the desired source, and adjust the volume with the volume control. If the source selector switch is set to COMMON, both CD and MD sources can be monitored. When both decks output a signal, the monitored source depends on the “COMMON?” option setting on the SYSTEM menu.

WARNING

When using headphones, take care not to turn the volume too high. Listening at high volumes for extended periods of time may result in permanent hearing damage.

Display master and remote master settings

For simple playback operation, the front panel keys or the remote control keys can be used. However, to ensure that the deck and disc information is properly shown on the display, the ‘display master’ setting must be selected for the deck in use. Also, when performing various playback operations by remote control, the ‘remote control master’ setting must be

selected for the deck in use. Refer to “Display master and remote control master” on page 20.

To prevent operation errors, we recommend that the display master and the remote control master be set for the same deck.

Track selection

Using the skip function

Select desired tracks for playback with the skip keys, ◀◀ / ▶▶ on the front panel, or ◀◀ / ▶▶ on the remote control. After selecting the track, press the PLAY key to start playback, or the READY key to cue the track and enter playback standby mode.

To restart playback from the beginning of the track in play, press the ◀◀ once. To skip to the previous track, press ◀◀ twice.

To skip to the next track, press ▶▶ once.

Selecting by track number

Using the number keys on the remote control, the number of the desired track can be entered directly. Even numbers with two or three digits can be entered easily. For example:

Track 9: press ‘9’ and 009 will be displayed.

Track 12: press ‘1’ and ‘2’ and 012 will be displayed.

Track 103: press ‘1’ and ‘0’ and ‘3’ and 103 will be displayed.

After input, press the PLAY key to start playback, or the READY key to cue the track and enter playback standby mode.

Search

During playback or playback standby, this function enables the search of a desired portion within a track for playback.

Front panel operation: press the ◀◀ / ▶▶ search key continuously.

Remote control operation: continuously press the ◀◀ / ▶▶ search key.

Be sure to hold the key down; if you quickly release it, the Skip function will operate.

NOTE

The Search function does not operate with MP3 discs.

Time Search function

By specifying time from the start of a certain track, you can start playback from a specified point of a specified track.

Basic operation

- 1 **During stop, play or playback standby modes, use the number keys on the remote control to input the three-digit track number (such as 002 for track 2), then the desired elapsed time (**min **sec) from the start of that track.**

Example: To specify 1 min 30 sec from the start of track 2, input “002 001 30.”

NOTE

For MP3 discs, time cannot be specified within a track. However, if you input the three-digit track number, playback will begin from the start of that track.

During input, the counter in the display will flash.

Regardless of the time display mode, the time from the start of the specified track is displayed.

When the final digit is entered, the desired position is automatically located. During stop or playback modes, playback will begin from the desired point. During playback standby mode, at the desired point the unit will enter playback standby mode.

NOTE

If a point which does not exist is selected, setting operation will be cancelled.

Auto cue

When the auto cue function is turned on, when a track is selected, the point where sound begins (not where the track begins) on that track is located, and the unit enters playback standby mode. Then, when the PLAY key is pressed, playback begins at exactly that point.

Auto cue on/off and the sound start position detection level can be set separately for CD and MD.

NOTE

Auto Cue functions only for MD tracks recorded in the ST mode. For MD tracks recorded in MONO, LP2 or LP4 modes, the Auto Cue function will only cue to the very beginning of the track.

When the Auto Cue function is on, A_CUE is lit on the display.

Operation variations

Even if the final second is not input, playback will begin from the selected point after pressing the PLAY key. Or, if you press the READY key, the unit will enter the playback standby mode at the selected point.

Track search

This is explained in the “Specifying by track number” part of “Track selection” on page 25.

After inputting the three-digit track number, press the PLAY key to begin playback of that track, or the READY key to cue the track and enter playback standby mode.

Specifying to the minute

After inputting the three-digit track number and the number of minutes after the start of the track, press the PLAY key to begin playback of that track, or the READY key to cue the track and enter playback standby mode.

Example: To specify 1 min 00 sec from the start of track 2, input “002 001.”

NOTE

Following the above example, if “0021” is input, the same position will be located.

NOTE

During the stop mode, to cue to the start of sound on track one, just press the READY key.

Turning the Auto Cue function on and off

Press the AUTO CUE key on the remote control to turn this function on and off.

You can also use the “A_CUE?” option on the PLAY sub-menu of the MD menu or CD menu to turn the Auto Cue function on and off for each deck. (Default position: OFF)

Even when the power is turned off, the Auto Cue setting is maintained.

Setting the sound start position detection level

Use the “A_CUE LEVEL?” option on the PLAY sub-menu of the MD menu or CD menu to set the sound start position detection level. Settings can be made independently for each deck. The level can be set between –72 dB and –24 dB in 6 dB increments.

NOTE

When the Auto Cue point is being searched, the > arrow flashes in the display, and audio output is muted.

Auto Ready

When the Auto Ready function is on, after each track is played, playback standby mode is entered at the start of the next track. Even when the Skip function is used to skip tracks, playback standby mode is entered at the start of the selected track.

NOTE

When the Auto Cue function is also on, playback standby mode is entered at the start of the sound on the selected track, and not the beginning of that track.

Turning the Auto Ready function on and off

Press the AUTO READY key on the remote control to turn the function on and off.

You can also use the “A_READY?” option on the PLAY sub-menu of the MD menu or CD menu to turn the Auto Ready function on and off for each deck. (Default position: OFF)

When the Auto Ready function is on, A.READY is lit on the display.

Even when the power is turned off, the Auto Ready setting is maintained.

Repeat playback

Press the REPEAT key on the remote control to turn on the Repeat mode. In this mode, all the tracks on the disc are played continuously. During playback, if the Repeat mode is turned on, playback continues as before, and when the last track finishes, playback resumes from the first track. If Repeat mode is turned on when the deck is stopped, press the PLAY key to begin operation.

You can also use the “REPEAT?” option in the PLAY sub-menu of the MD and CD menus to turn the Repeat mode on and off for each deck.

Combining the Repeat mode with the Program, Single-track playback and Random playback functions will enable Program Repeat, Single-track Repeat and Random Repeat operations, respectively.

A to B repeat playback

If a specific portion between two points on the disc is specified, that portion can be played back repeatedly.

- 1 During playback, press the A-B REPEAT key on the remote control at the beginning of the desired portion on the disc.**
“A-” flashes on the display.
- 2 At the end of the desired portion on the disc, press the A-B REPEAT key on the remote control again.**
“REPEAT” and “A-B” are lit up on the display, and the desired A-B section will be played repeatedly.

To cancel A-B Repeat mode and resume normal playback

Press the A-B REPEAT key once more.

In Random and Program modes, A-B Repeat cannot function when the specified A-B section spans more than one track.

When the STOP key is pressed, the specified A-B section is cancelled.

NOTE

A-B repeat playback will not function for two different tracks or on an MP3 disc.

Continuous CD and MD playback

With this function, when one deck finishes, the other deck begins play.

- 1 Turn on the **CONT PLAY** switch on the front panel.
- 2 Play a CD or MD.
When the disc finishes playback, the disc in the other deck begins playing automatically. When that disc finishes, the first disc is played again, and the playback cycle continues.

NOTE

During Continuous Play, the deck currently in playback automatically becomes the display master.

When the Repeat Mode is turned on, Repeat playback is performed instead of continuous playback.

That is, Repeat Mode has priority over the Continuous Play function.

To cancel Continuous Play operation, press the **STOP** key.

Timer Playback

By using an external timer, you can set the MD-CD1MKII to play the loaded disc automatically when the unit is turned on by the timer.

- 1 First, plug the power cord of the MD-CD1MKII into the power outlet of the timer.
- 2 Load a CD or an MD into the unit.
- 3 Use the “**TIMER PLAY?**” option on the **PLAY** sub-menu of the MD or CD menu to turn the timer function on for the desired deck.

When Timer Play has been turned on, the timer icon lights up in the display.

- 4 Set the timer to the desired time. Consult the timer’s operation manual for details. At the set time, the power to the MD-CD1MKII will be turned on, and playback will automatically begin.

NOTE

Only one deck can be selected for timer playback. This deck will become the display master during Timer Play operation.

Pitch control

When playing back an audio CD or MD, the pitch (or speed) of the playback can be varied. Pitch can be varied +/- 12.5% for MD, and +16% to -50% for CD.

NOTE

Pitch control does not function for MP3 discs.

Front panel operation

- 1 During stop, playback or playback standby mode, press the **PITCH** control for the desired deck to turn the Pitch Control function on.
- 2 Rotate the pitch control knob to set the pitch.

NOTE

*Use the “**PITCH STEP?**” option in the **PLAY** sub-menu of the MD and CD menus to adjust the pitch control steps from 0.1% to 1.0% in 0.1% increments. (Default: 0.1%)*

Remote control operation

- 1 During stop, playback or playback standby mode, press the **PITCH** key to turn the Pitch Control function on.
- 2 Use the **PITCH +/-** key to set the pitch. Pitch is adjusted in 0.1% increments.

NOTE

Pitch control only functions during normal playback. During recording, pitch control does not function.

For MD, when the pitch control function is on, there is no digital output of the playback signal. For CD, however, a digital signal is output.

When turning the pitch control on and off during playback, sound output is cut for a short instant.

Pitch control does not function for MD playback in LP2 mode.

Single-track playback

This function enables playback of just a single track.

During the Stop mode, press the P.MODE key on the remote control, and “SINGLE” lights up in the display.

After the selected track finishes, playback stops.

NOTE

If the Repeat function is also on, the selected track will be played repeatedly.

You can also use the “PLAY MODE?” option in the PLAY sub-menu of the MD and CD menus to set the Single-track playback mode.

Even when the power is turned off, the Single-track playback mode settings are retained.

Program playback

This function enables playback of selected tracks in any desired order. Up to 99 tracks can be selected from a CD, or up to 25 tracks from an MD, for Program playback.

- 1 During stop mode, press the P.MODE key on the remote control until “PROGRAM” is indicated on the display.

The program number and total program playing time will be shown on the character display.

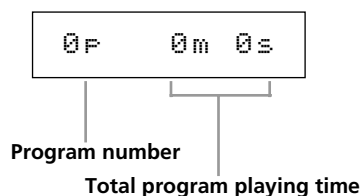

NOTE

You can also use the “PLAY MODE?” option in the PLAY sub-menu of the MD and CD menus to set the Program Playback mode.

- 2 Use the number keys on the remote control to select each desired track for program playback, then press the ENT/YES key. The track number will be entered into the program.

NOTE

To set the program by front panel operation, use the MULTI JOG dial to select the track number, then press the ENTER key to add the track to the program.

- 3 Repeat the above step 2 until the desired program is completed.

As the program is being created, the program number and total program playing time is revised on the display.

To confirm program contents, press the skip keys during playback or playback standby.

NOTE

If the total program playing time exceeds 999 min 59 sec for CD, or 715 min 49 sec for MD, “--- m -- s” is displayed.

- 4 When program setting is completed, press the PLAY key to begin playback of the tracks in the programmed order.

NOTE

If the STOP key is pressed without first pressing the PLAY key, all the program data will be erased.

Deleting a programmed track

- 1 During STOP mode, use the skip key to select the track for deletion. The track number will be shown in the display.
- 2 Press the DEL/CLR key.

NOTE

Right after STOP, if the DEL/CLR key is pressed, the last track programmed will be deleted.

Adding a track to the program

- 1 During STOP mode, using the skip keys, skip to the programmed track before the position you wish to add a track. The track number should be shown on the display.
- 2 Use the number keys to input the track number of the track to be added.
- 3 Press the ENT/YES key.

7 – CD and MD Playback—Random playback

NOTE

Right after *STOP*, if the number of the track to be added is input, and the *ENT/YES* key is pressed, the track will be added to the end of the program.

To add a track to the program by front panel operation, use the *MULTI JOG* dial to select the track number, then press the *ENTER* key.

Program limitations

With an MD, if the Group mode is on, programs that include more than one group cannot be created.

With MP3 discs, if the Directory mode is on, programs that include more than one directory cannot be created.

The same track may be repeated in a program.

When 99 CD tracks CD (or 25 MD tracks) are entered into a program, if you attempt to add a track, “PGM Full!” will be displayed, and no more tracks can be added.

Saving program data

When program playback has finished, or when the *STOP* key is pressed, and the deck stops, the program data is retained.

When the power is turned off, the Program playback mode remains on, but the program data is deleted.

When the deck is stopped, pressing the *STOP* key will delete the program data.

When the deck is stopped, pressing the *P.MODE* key will cancel the Program mode and delete the program data.

When the *PLAY* key is pressed but there is no program data, “PGM Empty!” will be displayed, and the deck will not operate.

Random playback

In this mode, the deck will play back all the tracks on the disc in completely random order, regardless of track number.

1 During stop mode, press the *P.MODE* key on the remote control until “RANDOM” is indicated on the display.

NOTE

You can also use the “PLAY MODE?” option in the *PLAY* sub-menu of the MD and CD menus to set the Random Playback mode.

2 Press the *PLAY* key and Random playback will begin.

NOTE

Even when the power is turned off, the deck will remain in *RANDOM* mode.

Time display switching

During MD or audio CD playback (or playback standby), when the *TIME* key on either the front panel or the remote control is pressed, the time display will switch through several modes in the following order.

Elapsed track time (no display light indication)

Remaining track time (REMAIN is lit in the display)

Elapsed disc time (TOTAL is lit in the display)

Remaining disc time (TOTAL and REMAIN are lit in the display)

NOTE

During MD playback, the remaining disc time indication, as with CD, shows the playback time remaining until the end of the disc. Please note that this may differ from the remaining time indicated when recording the MD.

When stopped, the total recording time is shown, regardless of the status of the *TOTAL* and *REMAIN* indicators.

When playing an MP3 disc, elapsed track time is always displayed, and the *TIME* key does not operate.

For details on time display during recording and recording standby on an MD deck, please refer to “Checking remaining MD time” on page 39.

Even when the power is turned off, the time display mode setting is retained.

End of disc/track warning

When nearing the end of a track or disc, a warning indication is shown on the display.

The number of seconds before the track/disc end that the warning is displayed can be set beforehand, so that when playback reaches that point, the “EOM” warning will begin flashing on the display.

To set the warning display time, use the “EOM TRK?” or “EOM DISC” options on the PLAY sub-menu of the MD and CD menus. Each can be set between 1 and 99 seconds in 1-second increments, or the warning display can be turned off.

NOTE

The “EOM” warning function does not work with MP3 discs.

Playback functions for CD only

The following playback functions are for CD only, and are not available for MD playback.

Changing the key of playback

The key of the music can be changed during CD playback. Please note that this feature does not operate with MP3 discs.

- 1 Use the “KEY LEVEL?” option on the PLAY sub-menu of the CD menu to change the key. The playback key can be raised or lowered 1/2 octave in half-tone increments. Selection values: 0 (no change), b1 to b6, #1 to #6
- 2 Press the KEY key on the front panel to turn the Key Change function on.

The “KEY” indication lights up in the display.

NOTE

Each time the KEY key is pressed, the function is switched on or off. When the function is on, instead of an “ON” indication, the key selected (in operation 1. above) is indicated on the display. For example: “Key b2”

In this condition, when a CD is played back, the key of the music is changed while the speed of the music remains the same.

NOTE

Even when the power is turned off, the key change setting is retained.

When the Key Change function is on, even if the Pitch Control function is used to change the playback speed, the key of playback will remain fixed at the preset key. (Even if the key level is 0 (zero), the Key Change function can be turned on.)

NOTE

When using the key control function, playback sound may occasionally sound like vibrating. This is a result of a special process applied to CD playback sound and is normal.

Fade-in and fade-out

When this function is on, when CD playback begins the song fades in, and when playback finished the song fades out.

- 1 To set the fade operation, use the menu options shown below. They can be found under the VOL FUNC sub-menu in the CD menu.

FADE IN

The length of the fade in to the normal level can be set between 1 and 30 seconds in 1-second increments. (Default setting: 3 seconds).

FADE OUT

The length of the fade out into complete silence can be set between 1 and 30 seconds in 1-second increments. (Default setting: 3 seconds).

FADE MODE

The deck can be set to continue playback (“Play”) or enter playback standby mode (“Ready”) after fade-out is completed.

- 2 In stop mode or playback standby mode, press the FADER key.
Playback begins and the sound fades in. After the preset fade-in time, the sound is at normal level.
- 3 During playback, press the FADER key when you wish to fade-out the sound.
Fade-out begins, and after the preset fade-out time, there is silence. After it becomes silent, depending upon the Fade mode setting, playback continues or the deck enters playback standby mode.

7 – CD and MD Playback—MP3 file directory playback

Output volume

The volume of the CD playback output signal can be adjusted. This adjustment functions for both for analog output (including headphone output) and digital output.

- 1 **Setting is made using the “PLAY VOLUME?” option on the VOL FUNC sub-menu of the CD menu.**

MP3 file directory playback

MP3 files recorded onto a CD are handled the same way as files are handled in an ordinary PC, with some MP3 files held within a directory. In addition, several directories can be combined into one directory. This results in multiple layers of directories and files.

When the Directory mode is on, only those files within a selected directory are available for playback. When the directory mode is off, the directory configuration is ignored, and all MP3 files recorded on the disc are available for playback. Please note that Program playback and Repeat playback only function within directories.

NOTE

Each MP3 file is handled as a track.

Directories which do not contain MP3 files directly under them cannot be selected for playback. For example, in the diagram below, under directory A are directory B and directory C. If there are MP3 files in both directory B and C, directory A cannot be selected for playback, but directory B and C can be selected for playback.

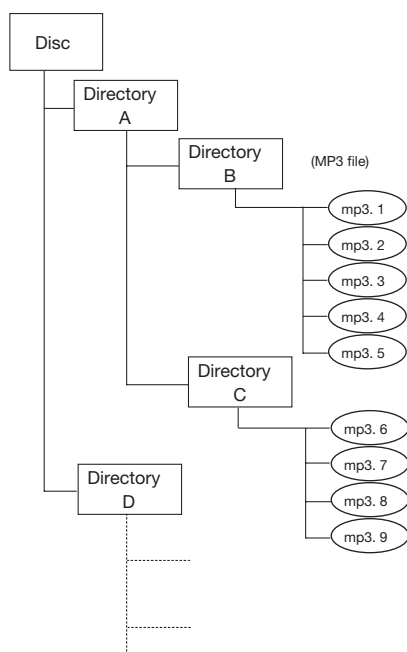

The level can be set between -54 dB and $+18$ dB, or “- -” (- infinity) can be selected.

NOTE

Since volume adjustment is performed in the digital domain, if the output level is excessive in the plus direction, digital distortion will be generated.

Directory playback setting

- 1 **Set the remote control master to CD, and press the DIR/GROUP key.**

“DIR ON” or “DIR OFF” will be shown in the display. When the DIR/GROUP key is pressed, the current setting is changed. For example, if the directory playback mode is off, when the key is pressed, the mode is turned on and “DIR ON” is displayed.

You can also use the “DIR MODE?” option in the PLAY sub-menu of the CD menu to turn this mode on or off.

- 2 **During Stop mode, the CD SEARCH key on the remote control can be used to select a directory.**

Press the CD SEARCH key, and the selected directory title will be shown on the display.

Setting MP3 ACTION

You can choose whether the unit continues playback or stop when MP3 playback fails (Decode Err!).

Select “MP3 ACTION?” option on the PLAY sub-menu of the CD menu. Select “Skip” or “Stop.”

• Skip

When MP3 playback fails (Decode Err), the unit skips the current track and advances to the next track. Playback will stop if the current track is the last track (i.e., if the repeat function is off and the current track is the last track on the disc or in the program). The display shows “Decode Err!.”

• Stop

When MP3 playback fails (Decode Err), the unit stops playback. The display shows “Decode Err!.”

NOTE

If MP3 playback fails during dubbing mode, the unit stops playback regardless of the MP3 ACTION setting.

MD group playback

The MD-CD1MKII allows MD tracks to be divided into groups.

When the Group mode is on, only those tracks in the selected group are available for playback. This is like playing a disc which only contains the tracks in a selected group. Accordingly, Program playback and Repeat playback only function within the group.

Group playback setting

- 1 Set the remote control master to MD, and press the DIR/GROUP key.**
“GRP ON” or “GRP OFF” will be shown in the display. When the DIR/GROUP key is pressed, the current setting is changed. For example, if the Group playback mode is off, when the key is pressed, the mode is turned on and “GRP ON” is displayed.
You can also use the “GRP MODE?” option in the PLAY sub-menu of the MD menu to turn this mode on or off.
- 2 During Stop mode, the MD SEARCH key on the remote control can be used to select a group.**
Press the MD SEARCH key, and the number of the selected group will be shown on the display, followed by the group title.

NOTE

When Group mode is on, regardless of the group, tracks which are not in the group cannot be played.

When Group mode is turned on, recording is not possible.

Creating and deleting groups

Using the “EDIT” sub-menu of the MD menu, groups can be created or deleted. Refer to “Creating a group” and “Deleting a group” in the “MiniDisc editing” section starting on page 43.

Titling groups

You can title the groups using the “TITLE” sub-menu of the MD menu. Refer to “Group title input” on page 45.

8 – Dubbing from CD to MD

The MD-CD1MKII makes it easy to dub from CD to MD. Selected tracks or the entire disc can be dubbed.

Basic dubbing operation

First, load the CD to be used as the dubbing source into the CD deck, then insert a recordable MiniDisc into the MD deck.

To dub the entire CD

While the CD deck is stopped, press the DUBBING key on either the front panel or the remote control.

To dub a selected track on the CD

During playback of the desired track, or when that track is cued and the deck is in playback standby mode, press the DUBBING key on either the front panel or the remote control.

When the track is finished dubbing, both decks will stop.

NOTE

Dubbing is performed in the preset recording mode and recording speed. For details, refer to the following.

Recording mode setting

Using the “REC MODE?” option on the REC sub-menu of the MD menu, select the recording mode from the following choices.

ST:	standard stereo recording mode	default, with no display indication
MONO	monaural recording mode	“MONO” lights up in the display
LP2	half-speed stereo recording mode	“LP2” lights up in the display
LP4	quarter-speed stereo recording mode	“LP4” lights up in the display

NOTE

In MONO mode, only the left channel is recorded, and the recording time is twice that in ST mode.

The recording time in LP2 mode is twice that in ST mode.

The recording time in LP4 mode is four times that in ST mode.

The remaining MD recording time indicated depends upon the recording mode setting.

Recordings made in different recording modes can be combined on the same disc.

Since a special data compression technology is used for LP4 mode (quarter-time recording for four times the recording time in stereo), there is the very slight possibility of spikes of noise being generated. If sound quality is an important consideration, we do not recommend the use of the LP4 mode.

Dubbing speed setting

Use the “REC SPEED?” option on the REC sub-menu of the MD menu to select either “NORMAL” or “HIGH” speed dubbing.

NORMAL: dubbing is performed during regular playback.

HIGH: dubbing speed depends on the MD recording mode, as indicated below.

MD recording mode	source disc	dubbing speed
Standard mode	audio CD	4X speed
MONO, LP2 or LP4 mode	audio CD	2X speed
—	MP3 disc	actual speed

To listen while dubbing, select NORMAL. For faster dubbing, select HIGH.

When Rec Speed is set to NORMAL, MD dubbing is possible even if the Key Change or Pitch Control functions have been used for CD playback.

9 – MD recording from an external source

The MD-CD1MKII can not only dub from CD to MD, it also allows MD recording from other sound sources.

Basic recording

Set the recording mode and select the input source. While monitoring the input signal, adjust the recording level. After all settings are complete, you are ready to make a recording.

Before following the procedures below, make sure the MD-CD1MKII power is on, a recordable Mini-Disc is in the deck, and the deck is in stop mode.

Recording mode setting

- 1 Use the “REC MODE?” option on the REC sub-menu of the MD menu to set the recording mode.

For more details, refer to the previous section “Dubbing from CD to MD” on page 34.

Input source selection

- 2 Use the INPUT SEL key on the front panel or the remote control to select the input source.

Press the key to switch between ANALOG and OPTICAL.

ANALOG

The analog signal from the ANALOG INPUT terminals is the recording source.

OPTICAL

The digital signal from the DIGITAL (OPTICAL) INPUT is the recording source.

Even if the power is turned off, the selected input source is retained.

Input monitoring

- 3 Press the RECORD key on either the front panel or the remote control.

The MD deck will enter recording standby mode, the READY and RECORD indicators will light up, and “REC” and “|” will light up on the display.

NOTE

The deck cannot enter recording standby mode in the following cases.

The tab on the MD cartridge is set to prevent recording, and “W_Protected” is displayed.

The disc is full, and “Disc Full!” is displayed.

The maximum number of tracks has been recorded, and “Track Full!” is displayed.

When the digital input (OPTICAL) is selected, if there is no proper digital signal input, “D-IN UNLOCK!” will be displayed, and recording cannot be performed.

NOTE

If a partially recorded disc is inserted, the end of the recorded portion will be detected.

The deck will enter recording standby mode, and the MD input signal can be monitored through headphones or a connected audio system.

NOTE

If monitoring through a connected system, connect the MD OUTPUTS terminals to the system. Connection through the COMMON OUTPUTS terminal is also possible, but in this case, the appropriate setting must be made using the “COM-MON?” option on the SYSTEM sub-menu of the CD menu. Refer to “Connecting analog audio equipment” on page 10.

For details on headphone monitoring, refer to “Basic playback operation” on page 24.

Even if no MD is inserted in the deck, it is still possible to monitor the input signal by pressing the RECORD key. In this case, “Monitor” will be shown in the display.

To cancel input monitoring, press the STOP key.

Recording level adjustment

Adjust the recording level while monitoring the input and viewing the meters.

- 4 Use the “REC VOLUME?” option on the VOL FUNC sub-menu of the MD menu to adjust the level.

If ANALOG is selected as the input source, you may also use the front panel INPUT controls (L and R) to set the level independently for each channel.

Recording start

- 5 In the recording standby mode, press the PLAY key, and recording will start.

To stop recording, press the STOP key.

After pressing the STOP key, “UTOC Writing!” will be shown on the display as the User Table Of Contents is written on the disc.

To pause recording, press the READY key.

To eject the disc from the deck, press the EJECT key during stop mode.

NOTE

When “UTOC Writing!” is flashing on the display, data on the recorded contents is being written onto the disc. During this process, if the power cord is unplugged from the power source, or the unit is moved or disturbed, this essential data cannot be correctly recorded on the disc.

Recording cautions

When “W_Protected!” is displayed

The inserted MD cannot be recorded, or a playback-only MD was inserted.

Close the write protect tab to enable recording.

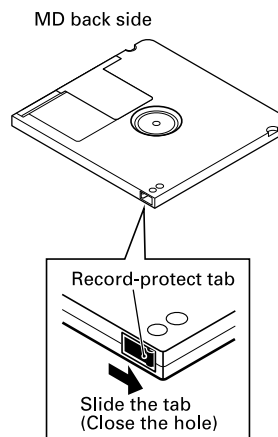

Adding track numbers

Track numbers are necessary for editing and cueing operation. During recording, track numbers are entered automatically, and may also be entered manually either during or after recording.

Auto track function

This function automatically enters track numbers during recording.

Set this function using the AUTO TRACK key on the remote control to select “OFF,” “-**dB,” “DD” or “TIME.”

You can also set the auto track function using the “A_TRK?” option in the REC sub-menu of the MD menu. (To set “-**dB,” select “Level” from the “A_TRK?” option.)

-**dB

If the signal falls below the Auto Track operation level for more than four seconds, a track number is automatically entered. To set this operation level, use the “A_TRK LEVEL?” option on the REC sub-menu of the MD menu. The level can be set between -24 dB to -72 dB in 6 dB increments.

DD

When recording from digital sources, track numbers are added in accordance with the source track numbers.

When recording from analog sources, track numbers are added when the input level drops for four seconds or more, in the same way as with the “-**dB” setting above.

TIME (Time Track Increment)

When the specified time (Auto Track operation time) has expired, track numbers will be updated automatically. Set this operation time using the “A_TRK TIME?” option on the REC sub-menu of the MD menu. The setting range is from one minute to 10 minutes (in one minute increments).

NOTE

Even when the power is turned off, the Auto Track, Auto Track Level and Auto Track Time settings are retained.

NOTE

If you change the Auto Track operation time during recording, the change will be applied beginning with the next track.

Entering a track number manually

During recording: press the RECORD key at the point where you wish to begin a new track.

After recording: track numbers can be entered during editing operation. Refer to “Divide tracks” on page 41.

Fade-in and fade-out recording

At the beginning and end of MD recording, fade-in and fade-out effects can be performed.

Before following the procedure below, make sure that basic recording preparations have been completed, a recordable disc is inserted, and the deck is in stop mode.

- 1 Set operation using the following menu options on the VOL FUNC sub-menu of the MD menu.**

FADE IN

The length of the fade in to the normal level can be set between 1 and 30 seconds in 1-second increments. (Default setting: 3 seconds).

FADE OUT

The length of the fade out into complete silence can be set between 1 and 30 seconds in 1-second increments. (Default setting: 3 seconds).

FADE MODE

The deck can be set to continue recording (“Rec”) or enter recording standby mode (“Ready”) after fade-out is completed.

- 2 In recording standby mode, press the FADER key.**

Recording begins and the sound fades in. After the preset fade-in time, the sound is at normal level.

- 3 During recording, press the FADER key when you wish to fade-out the sound.**

Fade-out begins, and after the preset fade-out time, there is silence. After it becomes silent, depending upon the Fade mode setting, recording continues or the deck enters recording standby mode.

NOTE

Fade-in or fade-out only may be selected.

The “Time Machine” recording function cannot be performed together with fade-in recording. For details, refer to the following section.

“Time Machine” recording

This function makes it possible to start recording up to 6 seconds before the time the recording operation is actually started. It operates by holding the input signal in a buffer memory that can be set to contain up to 6 seconds of data representing a normal stereo input signal.

Before following the procedure below, make sure that basic recording preparations have been completed, a recordable disc is inserted, and the deck is in stop mode.

- 1 Set the time value for the amount of data to be stored in the buffer using the “TM_REC?” option on the REC sub-menu of the MD menu.**

Setting values range from 1 to 6 seconds in 1-second increments, as well as OFF. The default setting is OFF.

OFF: The Time Machine function does not operate.

1 sec to 6 sec settings: The buffer will hold the corresponding seconds of signal.

- 2 Press the RECORD key to enter recording standby mode.**

- 3 Press the PLAY key to start recording.**

The signal will be recorded from the number of seconds set before the PLAY key is pressed.

- 4 Press the STOP key to stop recording.**

NOTE

When performing fade-in recording (explained in a previous section), Time Machine recording is not possible.

Overwrite recording

This function is used to record a new signal over a previously recorded but unwanted portion of the disc.

Before following the procedure below, make sure that basic recording preparations have been completed, a recordable disc is inserted, and the deck is in stop mode.

- 1 **Locate the point at which you wish to begin overwrite recording, press the READY key, and the deck will go into playback standby mode.**

To start overwrite recording from the beginning of a certain track, use the SKIP keys or the number keys to select the track, then press the READY key.

To start overwrite recording from the middle of a certain track, use the SKIP keys or the number keys to select the desired track, then press the PLAY key to begin playback (you can also use the Search function). At the desired point, press the READY key.

- 2 **Press the RECORD key, “Over Write” will be shown on the display, and the deck will enter recording standby mode.**

Adjust the recording level if necessary.

- 3 **Press the PLAY key and overwrite recording begins.**

NOTE

When “SINGLE,” “RANDOM” or “PROGRAM” lights up in the display, overwrite recording cannot be performed. In the case of step 2 above, “Can’t Rec” will be displayed.

Sync recording

The Sync recording function automatically begins recording when the signal from external equipment is present in the source input. Plus, if silence in the source signal continues for more than four seconds, the deck is automatically put into the recording standby mode.

Before following the procedure below, make sure that basic recording preparations have been completed, a recordable disc is inserted, and the deck is in stop mode.

- 1 **Press the SYNC key on the remote control to select on or off.**

You can also switch the SYNC recording function on or off using the “SYNC?” option on the REC sub-menu of the MD menu.

- 2 **Set the signal detection threshold level using the “SYNC LEVEL?” option on the REC sub-menu of the MD menu. The level can be set from –72 dB to –24 dB in 6 db increments. The default setting is –54 dB.**
- 3 **Press the RECORD key to enter recording standby mode.**

NOTE

In this status, recording will begin as soon as a source signal is input.

- 4 **Input the source signal.**

When a source signal is detected, recording begins automatically.

If the signal is under the threshold level for over four seconds, the deck automatically enters recording standby mode.

NOTE

During SYNC recording standby, recording cannot be started manually by pressing the PLAY key.

- 5 **To manually stop recording, press the STOP key.**

NOTE

During SYNC recording, even if the READY key is pressed, the recording standby mode cannot be entered. (The key cannot be used to pause recording.)

The INPUT SEL key does not function during SYNC recording.

After SYNC recording finishes and the deck enters recording standby mode, if the power is turned off the recording data will be deleted. Make sure to press the STOP key so that the U-TOC is written onto the disc before turning the power off.

Checking remaining MD time

During MD recording or recording standby mode, press the TIME key on either the front panel or the remote control, and the elapsed track recorded time and remaining recording time will be shown in succession on the display.

Elapsed track recorded time (no indication light)

Disc remaining time (REMAIN only, or TOTAL and REMAIN will light up)

Even if the power is turned off, the time settings will be retained.

10 – MiniDisc editing

Tracks recorded can be deleted, moved, divided or combined by MiniDisc editing operation.

Editing operations

All MD editing functions are operated from the EDIT sub-menu on the MD menu.

After selecting a menu option on the EDIT sub-menu, subsequent operation will vary. Specific operations for each menu option are explained individually in the following section.

NOTE

Editing functions cannot be performed on discs set to prevent accidental erasure (write protected), and "W_Protected!" will be displayed when accessing the EDIT sub-menu of the MD menu.

Tracks and points for editing

For most editing menu options, if the deck is not in play or in playback standby mode at the track or point to be edited, the option itself cannot be

selected, and "Can't Edit!" will be displayed. These are options for editing functions to be performed on tracks or points, including DIVIDE, COMBINE and MOVE. The ERASE TRK option is called up before the track has been selected.

Canceling edits

To cancel editing operations up to the point where the setting screen or confirmation screen ("Sure?") appears, press the NO key, the MD STOP key, or the MD MENU key (MENU key on the remote control).

NOTE

After editing operations have been completed, with the MD still inserted and "TOC" lit up on the display, if the power is turned off, the revised U-TOC will not be written on the disc, and the editing operation will not be retained on the disc.

UNDO an edit operation

It is possible to cancel the most recently performed editing operation.

- 1 Stop the MD deck.
- 2 Select the "UNDO?" option from the EDIT sub-menu. Undo> *** is displayed, with *** representing the last performed editing option.

- 3 Press the ENTER key (or the YES key) on the front panel, or the ENT/YES key on the remote control.

"Sure?" is displayed.

- 4 Press the ENTER key (or the YES key) on the front panel, or the ENT/YES key on the remote control.

The last editing operation performed will be undone.

Erase track

Unwanted tracks can be erased one at a time

Example: To erase B in track number 2

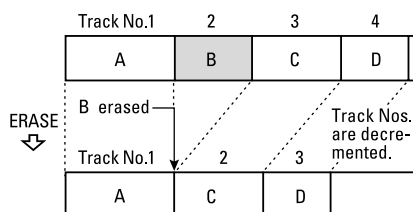

Selecting a track to be erased by playback

- 1 The deck should be in play or in playback standby on the track to be erased.

- 2 Select the "ERASE TRK?" option on the EDIT sub-menu of the MD menu.

"Sure?" is displayed.

- 3 Press the ENTER key (or the YES key) on the front panel, or the ENT/YES key on the remote control.

After the track is erased, "Complete" is shown on the display.

Selecting a track to be erased on the menu

- 1 In the stop mode, select the “ERASE TRK?” option on the EDIT sub-menu of the MD menu.
“Track>***” will be displayed, with *** representing the last track number.
- 2 Select the track to be erased using the MULTI JOG dial on the front panel, or the MENU +/- key on the remote control, and press the ENTER key.
“Sure?” is displayed.

- 3 Press the ENTER key (or the YES key) on the front panel, or the ENT/YES key on the remote control.

After the track is erased, “Complete” is shown on the display.

NOTE

When a track is erased, the tracks are renumbered from the next track.

Erase disc

All the tracks on the disc can be erased in one operation.

- 1 Select the “ERASE DISC?” option on the EDIT sub-menu of the MD menu.
“Sure?” is displayed.
- 2 Press the ENTER key (or the YES key) on the front panel, or the ENT/YES key on the remote control.
After all the tracks on the disc are erased, “Complete” is shown on the display.

Divide tracks

Tracks can be divided into two or more tracks.

Example: To divide C and D contained in track number 3 into two tracks

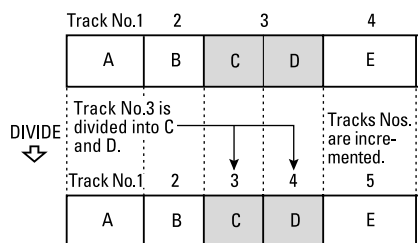

- 1 Select the “DIVIDE?” option on the EDIT sub-menu of the MD menu.
- 2 Play back the track to be divided, and at the desired divide point, press the ENTER key (or the YES key) on the front panel, or the ENT/YES key on the remote control.
“Point> 0” is displayed, and starting at the divide point (specified in the above operation) a few seconds are played back repeatedly to enable confirmation.

NOTE

As an alternate procedure to steps 1 and 2 above, play the track to be divided, and at the desired point, put the deck into playback standby mode. Then select the “DIVIDE?” option on the EDIT sub-menu of the MD menu, and “Point> 0” will be displayed. Starting at the divide point (specified in the above operation) a few seconds are played back repeatedly to enable confirmation.

- 3 If necessary, use the MULTI JOG dial on the front panel, or the MENU +/- key on the remote control to adjust the divide point.
- 4 After the divide point has been set, press the ENTER key (or the YES key) on the front panel, or the ENT/YES key on the remote control.
“Sure?” is displayed.
- 5 Press the ENTER key (or the YES key) on the front panel, or the ENT/YES key on the remote control.
After the track is divided, “Complete” is shown on the display.

NOTE

If a title has been added to the track, it will be retained only for the first of the new divided track. The second divided track will not have a title.

Combine tracks

Two successive tracks can be combined into one track by deleting the track mark of the second track.

Example: To combine B and C

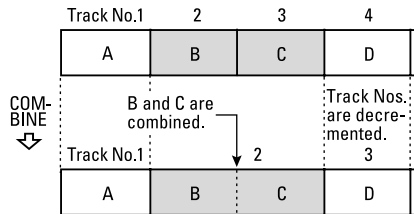

NOTE

Successive tracks recorded with different recording modes cannot be combined into a single track.

- 1 Put the deck in play or in playback standby on the second of the two tracks to be combined.

For example, if tracks 2 and 3 are to be combined, play track 3 or put it in playback standby mode.

- 2 Select the “COMBINE?” option on the EDIT sub-menu of the MD menu.

“Track OK?” is displayed, and a 3-second segment from the end of the first track and a 3-second segment from the start of the second track are successively played back repeatedly to enable confirmation.

- 3 Press the ENTER key (or the YES key) on the front panel, or the ENT/YES key on the remote control.

After the tracks are combined, “Complete” is shown on the display.

NOTE

If both tracks have titles, the combined track will take the title of the first of the two tracks.

Move tracks

Tracks can be moved to different positions in the playing order.

Example: To move D from track number 4 to track number 2

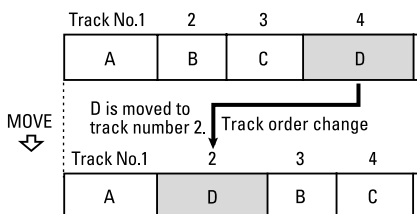

- 1 Put the deck in play or in playback standby on the track to be moved.

NOTE

If the above step is not performed first, and the following operations are performed while the deck is in stop mode, the last track will automatically be selected as the track to be moved.

- 2 Select the “MOVE?” option on the EDIT sub-menu of the MD menu.

“Move ***>### “ is displayed, with *** representing the number of the track to be moved, and ### representing the track number where it will be moved.

- 3 Use the MULTI JOG dial on the front panel, or the MENU +/- key on the remote control to select the track number where it will be moved.

- 4 Press the ENTER key (or the YES key) on the front panel, or the ENT/YES key on the remote control.

“Sure?” is displayed.

- 5 Press the ENTER key (or the YES key) on the front panel, or the ENT/YES key on the remote control.

After the track is moved, “Complete” is shown on the display.

Creating a group

The MD-CD1MKII enables tracks to be divided into groups on a single MD disc for playback by group. Refer to “MD group playback” on page 33.

A group is created by specifying track numbers of the “starting” track and the “ending” track.

- 1 In stop mode, select the “GRP CREATE?” option from the EDIT sub-menu of the MD menu.**
“ST Trk> 001” is displayed. This shows the starting track selection.
- 2 Use the MULTI JOG dial to select the starting track.**
- 3 Press the ENTER key (or the YES key) on the front panel, or the ENT/YES key on the remote control.**
“ED Trk>***” is displayed. This shows the ending track selection.
- 4 Use the MULTI JOG dial to select the starting track.**

- 5 Press the ENTER key (or the YES key) on the front panel, or the ENT/YES key on the remote control.**

“Sure?” is displayed.

- 6 Press the ENTER key (or the YES key) on the front panel, or the ENT/YES key on the remote control.**

After the specified group is created, “Complete” is shown on the display.

Disc title when creating a group

When creating a group, a disc title containing the group information or the group title is automatically created.

For example, if the original title of the disc is “Favorites” and tracks 1 to 4 are combined into a group titled “Jazz” and tracks 5 to 8 are combined into a group titled “Latin,” the new title of the disc will be:

0; Favorites//1-4; Jazz//5-8; Latin//

If titles are not given to the disc and the groups, the new disc title will be:

0; //1-4; //5-8; //

Deleting a group

Groups can also be deleted.

- 1 In stop mode, select the “GRP CANCEL?” option from the EDIT sub-menu of the MD menu.**
“GRP No> 01” is displayed.
- 2 Use the MULTI JOG dial to select the number of the group to be deleted.**
If all the current groups are to be deleted, select “ALL.”

- 3 Press the ENTER key (or the YES key) on the front panel, or the ENT/YES key on the remote control.**

“Sure?” is displayed.

- 4 Press the ENTER key (or the YES key) on the front panel, or the ENT/YES key on the remote control.**

After the specified group is deleted, “Complete” is shown on the display.

11 – Title input

Titles can be given to the MD disc, and the tracks and groups on it, using the TITLE sub-menu on the MD menu.

NOTE

Just as with the editing menu, after the title is selected and entered on the disc, and TOC lights up on the display, if the power is turned off, the U-TOC will not be recorded onto the disc, and the titles will not be added.

Disc title input

- 1 In the stop mode, select the “TITLE INPUT?” option on the TITLE sub-menu on the MD menu.

“Title> Disc” will be displayed.

- 2 While “Title> Disc” is displayed, press the ENTER key or the ENT/YES key on the remote control.

The current disc title is shown on the character display, title edit mode is entered, and the cursor flashes.

NOTE

If there is no current title, nothing will be shown on the display, and only the cursor will flash.

If a group is set, the default title automatically created by the MD-CD1MKII will be displayed. Refer to “Creating a group” on page 43.

- 3 Add a title following the guidelines below, and press the MD MENU key or the MENU key on the remote control to confirm.

NOTE

For discs with groups, set the Group mode to on before inputting a title. If a title is added with the Group mode off, the group settings may become inoperative.

Title input operation

In Title Input mode, the cursor flashes in the character display. Since it is more efficient to use the remote control to input titles, the following explanation will center on its use.

NOTE

It is even more efficient to connect a keyboard for title input. Refer to “Title input by keyboard” on page 46.

Follow the guidelines below to input titles on the screen.

Select the type of character for input

Press the CHAR key on the remote control to select from three different types of characters.

Lower case letters/code: no indication

Capital letters/code: CAPS

Japanese: カタカナ

For front panel operation, use the DISPLAY key.

Input procedure

Use the number keys to input characters at the cursor position.

Press the number keys the necessary number of times to get the desired character to appear on the display.

For front panel operation, use the MULTI JOG dial.

To move the cursor position

Use the skip keys.

However, if a different number key is pushed, the cursor automatically moves to the right.

For front panel operation, use the skip keys.

To delete characters

Set the cursor on the character to be deleted, then press the DEL/CLR key.

For front panel operation, use the NO key.

To insert characters

Move the cursor to the location where you wish to insert a character, and press the INS key.

For front panel operation, use the YES key.

To change a character

Set the cursor on the character to be changed, then input the desired character.

NOTE

As with the Editing menu, after the name is set, if the power is turned off while the MD is still inserted (TOC lights up), the revised U-TOC will not be recorded on the disc, and the title will not be input. The U-TOC is recorded when the disc is ejected.

Track title input

Method 1

With this method, the tracks for title input are selected first.

- 1 Put the deck in playback or playback standby mode on the track you wish to add a title. During recording, you may also input a title for the current track being recorded.
- 2 Select the “TITLE INPUT?” option on the TITLE sub-menu of the MD menu, and press the ENTER key on the front panel, or the ENT/YES key on the remote control.

The title of the track in play will be shown on the character display, Title Edit mode is entered, and the cursor flashes.

NOTE

If there is no track title, only the cursor will flash and nothing will be displayed.

- 3 Following the title input guidelines above, input the title, and press the MD MENU key on the front panel or the MENU key on the remote control to confirm.

Method 2

With this method, the Title Input mode is selected first.

- 1 During stop mode, select the “TITLE INPUT?” option on the TITLE sub-menu on the MD menu.
“Title> Disc” is displayed.
- 2 Select the track for title input using the MULTI JOG dial on the front panel, or the MENU +/- key on the remote control, then press the ENTER key on the front panel or the ENT/YES key on the remote control.

For example, select “Title> 003” to choose track 3.

When a selection is made, the current track title is shown on the character display, Title Edit mode is entered, and the cursor flashes.

NOTE

If there is no track title, only the cursor will flash and nothing will be displayed.

- 3 Following the title input guidelines above, input the title, and press the MD MENU key on the front panel or the MENU key on the remote control to confirm.

Group title input

- 1 During stop mode, select the “TITLE GRP?” option on the TITLE sub-menu on the MD menu.

“Title Grp> **” is displayed, with ** representing the group number.

- 2 Press the ENTER key on the front panel or the ENT/YES key on the remote control.

The current group title is shown on the character display, Title Edit mode is entered, and the cursor flashes. The group number flashes on the track number display.

- 3 Following the guidelines for title input methods above, input the title, and press the MD MENU key on the front panel or the MENU key on the remote control to confirm.

12 – Using a computer keyboard

A computer keyboard can be connected to the IBM PC compatible PS/2 interface on the front panel to

operate certain functions of the MD-CD1MKII. It is particularly efficient for title input.

Keyboard type setting

The MD-CD1MKII must be set for the type of keyboard being connected.

- 1 Set the type using the “KEYBOARD?” option on the SYSTEM sub-menu of the CD menu.**

Select **US** for an English-language keyboard, or **JP** for a Japanese-language keyboard.

Title input by keyboard

Titles can be input just like typing on a PC.

To enter the Title Edit menu

Press SHIFT + F7 to enter the Group Title Edit Menu.

“Title Grp>##” is shown on the display.

Press SHIFT + F8 to enter the Disc/Track Title Edit Menu.

“Title> ##” is shown on the display.

To select the type of characters for input

Press CAPS to select or cancel upper case letters

Press the **カタカナ** (katakana) key to select or cancel Japanese characters (Japanese-language keyboards only)

If both of the above are cancelled, lower case letters are input

To input characters

Character input is performed directly with the letter and number keys.

To move the cursor

Use the cursor arrow keys ← and →).

To delete characters

Delete key: deletes the character in the cursor position

Back space key: deletes the character before the cursor position

To insert a character

Use the Insert key.

To change a character

Put the cursor on its position and input the desired character.

12 – Using a computer keyboard—Other keyboard operations

Other keyboard operations

The keyboard can be used not only for title input, but also to control the deck transports, perform editing functions and other operations. The list below shows the keys that perform various operations.

Keyboard key	Operation
F1	MD ◀◀
F2	MD ▶▶
F3	MD key
F4	MD STOP
F5	MD PLAY
F6	MD READY
F7	AUTO CUE for MD
F8	MD RECORD
F9	AUTO READY for MD
F10	REPEAT for MD
F11	PLAY MODE for MD
F12	same as pushing the MD PITCH control
Keyboard key	Operation
SHIFT + F1	MD EDIT “ERASE TRK”
SHIFT + F2	MD EDIT “ERASE DISC”
SHIFT + F3	(inoperative)
SHIFT + F4	MD EDIT “MOVE”
SHIFT + F5	MD EDIT “DIVIDE”
SHIFT + F6	MD EDIT “COMBINE”
SHIFT + F7	TITLE EDIT “TITLE GRP”
SHIFT + F8	TITLE EDIT “TITLE INPUT”
SHIFT + F9	UNDO
SHIFT + F10	MD EDIT GRP CANCEL
SHIFT + F11	MD EDIT GRP CREATE

SHIFT + F12	DUBBING
CTRL + F1	CD ◀◀
CTRL + F2	CD ▶▶
CTRL + F3	CD key
CTRL + F4	CD STOP
CTRL + F5	CD PLAY
CTRL + F6	CD READY
CTRL + F7	AUTO CUE for CD
CTRL + F8	KEY key
CTRL + F9	AUTO READY for CD
CTRL + F10	REPEAT for CD
CTRL + F11	PLAY MODE for CD
CTRL + F12	same as pushing the CD PITCH control
CAPS	Select or cancel upper case letters
カタカナ	(katakana) to select Japanese characters (Japanese-language keyboards only)
←/→	to move the cursor
Delete	Same as the DEL/CLR key
Back space	deletes the character before the cursor
Insert	Same as the INS key
ESC	Cancel edit or title edit and finish Menu mode
Enter	ENTER/YES key

Data communication settings

By connecting a PC through its RS-232C terminal to the MD-CD1MKII through its CONTROL I/O (RS-232C) terminal, the two units can be linked for data exchange. Use the following options on the SERIAL sub-menu of the CD menu to perform their respective settings.

BAUD RATE

Sets the communication speed of the keyboard.

4800 / 9600 / 19200 / 38400 bps can be selected.

Default: 9,600

LENGTH

Communication word length can be set to either 7 or 8 bits.

Default: 8 bits

PARITY

Communication parity can be set to NON, EVEN or ODD.

Default: NON

STOP BIT

The data stop bit can be set to either 1 or 2.

Default: 1

Viewing service data

You can view service data via the following items in the SYSTEM submenu of the CD menu.

CD P_TIME

The total CD playback time is shown.

MD P_TIME

The total MD playback time is shown.

MD R_TIME

The total MD recording time is shown.

Initializing all data

You can reset all data to initial default settings.

- 1 Make sure that no disc is loaded in the MD or CD player. Select the “F_PRESET?” option on the SYSTEM sub-menu of the CD menu.**

The display indicates “Sure?.”

- 2 Press the ENTER (or YES) key on the unit or the ENT/YES key on the remote control.**

All data will be initialized to the default settings.

WARNING

Do not turn off the power to the unit until the “Complete” indicator on the display disappears.

CD section

CD-R/RW discs that have not been finalized cannot be played back. Make sure the disc has been properly finalized before loading into the player.

About finalization

Even if audio data is recorded onto a CD-R/RW disc, if the TOC (table of contents corresponding to the recorded data) is not written on the disc after recording, the disc cannot be played back on conventional CD players. “Finalization” is the process of writing the TOC on the disc.

A number of record companies have released titles on ‘copy control’ CD discs as a means of protecting artist copyrights. Some of these discs do not comply with standard CD format specifications, and may not be able to be played on this unit.

The MD-CD1MKII can play back MP3 files recorded in formats which conform to ISO9660 level 1, level 2, or Joliet. Discs recorded in multiple sessions may also be played back.

For MP3 CDs to be played by the MD-CD1MKII, the following limitations have been placed on the number of MP3 files and directories.

Maximum number of directories: 255

Maximum number of hierarchical structures: 8

Maximum number of MP3 files: 999

Maximum title size of MP3 files and directories: 255

MP3 files are played in the following order:

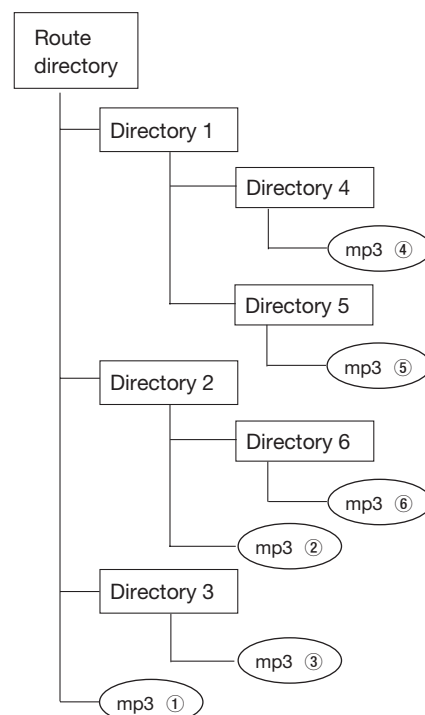

In this manner, playback is performed from the top level directories.

About MP3 track data

During playback, titles are displayed in the following order of priority:

ID3v2 > ID3v1 > file title

During stop mode, the file title is displayed.

MD section

Even when the maximum recording time is not reached, “Track Full!” is displayed.

Regardless of the time, when the maximum number of tracks has been reached, “Track Full!” is displayed. In the MiniDisc format, the number of tracks is limited to 255. To make an additional recording on discs with 255 tracks, unwanted tracks must be deleted, or tracks must be combined to reduce their number. If this is not possible, the additional recording must be made on a separate disc.

Even if the number of tracks or the recording time has not been exceeded, the “Track Full!” message is displayed.

If a great deal of emphasis data has been present, in order to use the track divisions in the same way, “Track Full!” is displayed regardless of the time or number of tracks.

Although tracks have been deleted, the remaining time on the MD disc does not increase.

When the remaining time on an MD disc is displayed, sections less than 12 seconds are ignored. So even if short tracks are eliminated, the total time indicated does not increase.

When elapsed recording time and remaining time are added up, it doesn't match the possible recording time of the MD disc.

Normally, the shortest possible recording unit is 1 cluster (about 2 seconds). Even if the recording is less than this, 2 seconds of space is taken up on the disc, so the actual possible recording time may be less than expected. Furthermore, if a scratch occurs on the disc itself, the area where it exists is automatically voided for use, so the recording time possible in that section is subtracted from total recording time.

Tracks cannot be combined.

Tracks created through editing operation may not be able to be combined with other tracks. If the recording mode (ST, MONO, LP2 or LP4) of two tracks differs, they cannot be combined.

If three or more tracks are to be combined, tracks less than a certain length (depending upon recording mode) cannot be used. The approximate minimum times are 9 seconds for ST mode, 17 seconds for MONO and LP2 mode, and 33 seconds for LP4 mode.

When search operation is performed, the sound breaks up.

When searching on tracks created through editing operations, the sound will sometimes break up.

When dubbing from CD to MD, space is created between tracks.

In order to properly record the cueing positions between tracks, space of a certain length is created. If such spaces between tracks are not desired, make the following settings before dubbing.

- Connect the CD digital output to the MD digital input
- Select OPTICAL as the input source
- In the REC sub-menu of the MD menu:
 1. Set the SYNC MODE option to ON
 2. Set the A_TRK option to DD

Track numbers are not properly entered.

When recording a CD through a digital connection, short tracks are sometimes created depending upon the recorded content of the CD. Also, when the Auto Track function is used and track numbers are automatically generated, depending upon the program material, the track numbers are not properly assigned.

The “UTOC Reading” indication stays on for a longer time.

When a new recordable MD disc is used, the “UTOC Reading” indication is displayed longer than usual.

For title input, less than 1,700 characters are available.

The title recording area is divided into 7-character units. Even if a title is created with less than 7 characters, that amount of space is still taken up. Therefore, in actual use, you may not be able to input a total of 1,700 characters.

15 – Message display glossary

Operation messages

Message	Details / response
Blank Disc	A blank recordable MD disc has been inserted.
New Disc!	A new recordable MD disc has been inserted.
Complete	Editing operation has been successfully completed.
Dubbing Wait	The unit is being readied for dubbing.
TOC Reading	The table of contents data is being read.
UTOOC Writing	The user table of contents data is being written to the disc.
Now Editing	Editing operation is being performed.
Over Write	Overwrite recording mode is on.

Error Messages

Message	Details / response
Disc Error!	The disc has malfunctioned. Please replace with a new disc.
Disc Full!	No recording time remaining on the disc, so new recording is not possible.
Title Full!	No more titles can be recorded.
D-IN UNLOCK!	The digital input is not connected. Turn on the power of the equipment connected to DIGITAL IN.
Not Execute!	Editing cannot be completed due to MD system limitations.
Not Audio!	There is no audio signal from DIGITAL IN.
No Track!	There are no recorded tracks.

PGM Empty!	There is no program
PGM Full!	No new programs can be created.
W_Protected!	Write-protected MD disc, so recording or editing is not possible.
Pre Master!	A playback-only MD disc has been inserted.
TOC Error!	TOC data is not correct.
Can't Edit!	Editing cannot be performed due to MD system limitations or editing condition limits.
Can't Rec!	Recording cannot start because the Group mode is on.
Can't Sel!	Menu selection cannot be performed due to selection prohibitions.
Can't Undo!	You can't undo since no editing has been done.
Rec Error!	There was an error during recording. Please re-record.
Drive Error!	There is a problem in the drive.
Sync Rec ON!	The Sync mode is on, so the recording cannot be started manually.
Err Group!	There is a problem in the data of the created group.
No Group!	No groups have been created.
No DIR!	The directory where the file is has not been registered.
Decode Err!	The MP3 file cannot be played back.
IR Disable!	All remote control operations are disabled.
Format Err!	The unit does not support the format of the MP3 files on the disc.

Troubleshooting

There is no power to the unit.

Please check that the power cord is properly plugged in.

“Disc Error!” is displayed.

The disc may be dirty. Please replace the disc.

Playback is not possible.

This may be due to condensation. In this case, remove the disc, turn the power on and wait a few hours, then try again.

No sound is output.

Confirm the connections with the audio system.

Check the volume level, and proper amplifier operation.

Recording isn't possible.

- The MD disc is set to write protect. Slide the tab on the cartridge to the closed position and try again.
- Confirm the connections with the audio system.
- Adjust the recording level.
- The disc may be for playback only. Please replace it with a recordable MD disc.
- Remaining recording time on the MD is insufficient. Please delete unwanted tracks or replace the MD disc.
- Confirm amplifier operation.

Noise or static can be heard.

Please re-position the unit away from strong sources of magnetism such as a television.

The MD-CD1MKII does not retain settings.

While settings are retained each time they are made, in some cases they will not be retained when the power is turned off too soon. To prevent this from happening, do not turn off the power right after making a setting.

16 – Specifications

MD deck

Type	MiniDisc recorder
Discs	MiniDisc format
Rec modes	Stereo/Mono/LP2/LP4
Recording format	Magnetic field modulation overwrite
Recording time	74 minutes (stereo), 148 minutes (mono), 148 minutes (LP2), 296 minutes (LP4) when using a 74-minute disc
Sampling frequency	44.1 kHz
Compression system	ATRAC (Adaptive Transform Acoustic Coding)

CD deck

Type	Compact Disc player
Discs	CD/CD-R/CD-RW
Formats	Audio CD (CD-DA), MP3

Rated input/output

Analog line input (MD input)	
Connectors	RCA
Input level	-10 dBV
Input impedance	10 k Ω
Analog line outputs	
Connectors	RCA
Output level	-10 dBV
Output impedance	570 Ω
Headphones	
Connectors	standard stereo jack
Max. output level	20 mW + 20 mW
Load impedance	32 Ω
Digital input	
Format	TOS (EIAJ RC-5720) IEC60958 Type II (S/PDIF)
Digital output	
Format	TOS (EIAJ RC-5720) IEC60958 Type II (S/PDIF)
Keyboard	Mini DIN 6-pin

MD specifications

Frequency response	20 Hz to 20 kHz +/- 0.5 dB
S/N ratio	> 98 dB (playback, A filter), > 95 dB (recording, A filter)
Dynamic range	> 98 dB (playback, A filter), > 95 dB (recording, A filter)
Total harmonic distortion	< 0.004% (playback), < 0.006% (recording)
Channel separation	> 90 dB (playback, at 1 kHz), > 83 dB (recording, at 1 kHz)

CD specifications

Frequency response	20 Hz to 20 kHz +/- 0.8 dB
S/N ratio	> 100 dB (A filter)
Dynamic range	> 100 dB (A filter)
Total harmonic distortion	< 0.004%
Channel separation	> 90 dB (at 1 kHz)
Wow and flutter	below measurable limits (less than 0.001%)

16 – Specifications—Dimensional drawing

Unit specifications

Power	USA/Canada 120 VAC, 60 Hz U.K./Europe 230 VAC, 50 Hz Australia 240 VAC, 50 Hz
Power consumption	18 W
Dimensions	483 x 94 x 308 mm 19 x 3.7 x 12.1 (in)
Weight	5.4 kg (11.9 lbs)
Operating temperature range	Operating temperature range: 5 to 40 degrees C (41°F to 104°F)
Supplied accessories	remote control unit (1) AA batteries (2) power cord (1) rack-mounting kit (1) owner's manual (1) warranty (1)

For product improvement, specifications and external appearance are subject to change without notice.

Due to product improvement, the actual unit may appear differently than the illustrations in the operation manual.

Dimensional drawing

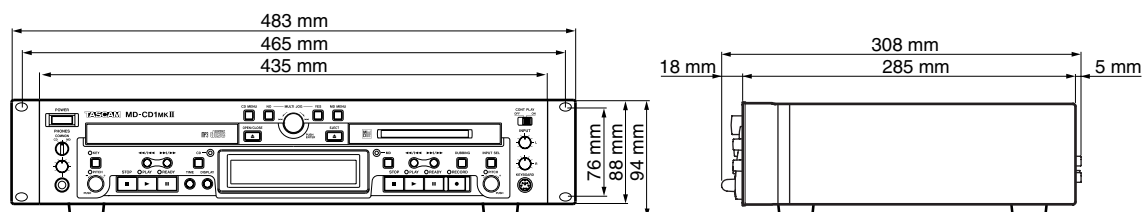

TASCAM

TEAC Professional Division

MD-CD1MKII

TEAC CORPORATION

Phone: +81-422-52-5082
3-7-3, Nakacho, Musashino-shi, Tokyo 180-8550, Japan

www.tascam.com

TEAC AMERICA, INC.

Phone: +1-323-726-0303
7733 Telegraph Road, Montebello, California 90640

www.tascam.com

TEAC CANADA LTD.

Phone: +1905-890-8008 Facsimile: +1905-890-9888
5939 Wallace Street, Mississauga, Ontario L4Z 1Z8, Canada

www.tascam.com

TEAC MEXICO, S.A. De C.V

Phone: +52-555-581-5500
Campeños No. 184, Colonia Granjes Esmeralda, Delegación Iztapalapa CP 09810, Mexico DF

www.tascam.com

TEAC UK LIMITED

Phone: +44-1923-438880
5 Marlin House, Croxley Business Park, Watford, Hertfordshire. WD1 8TE, U.K.

www.tascam.co.uk

TEAC EUROPE GmbH

Phone: +49-611-71580
Bahnstrasse 12, 65205 Wiesbaden-Erbenheim, Germany

www.tascam.de